

arthema[®]
S Y S T E M
Catalogo Tecnico 2009 .1

Gentile Cliente, per una facile lettura del catalogo, Vi invitiamo a consultare questa legenda.
 Dear Customer, please read the following guidelines for a better understanding of our catalogue.
 Sehr geehrter Kunde, bitte lesen Sie die folgenden Zeichenerklärungen für ein besseres Verständnis unseres Katalogs.
 Cher client, pour simplifier la lecture du catalogue, Vous pouvez consulter cette légende.
 Уважаемый клиент, для лучшего понимания Каталога предлагаем Вам прочесть данное толкование.

TYPE 20	COD.	A (mm)	B (mm)	KG	mm
	AL2001--0000	600	350	0,89	40
	AL2002--0000	900	350	1,32	35

Barra appenderia staccata.
 Outfstanding hanging bar.
 Lose Abhängestange.
 Barre d'accrochage décalée.
 Выступающее вешало.

① **Immagine prodotto - Item picture - Abbildung artikel - Image produit - Изображение артикула**

In questa casella è riportata un'immagine indicativa del prodotto non imballato; si precisa che tale immagine è da considerarsi come una rappresentazione grafica non vincolante ai fini delle caratteristiche tecniche del prodotto.
 This box contains a picture of the unpacked article. This picture is just as an indication, and it is therefore meant as a graphic representation, which is not as worth as a technical report.
 Auf diesem Kästchen steht eine Abbildung des unverpackten Artikels. Diese Abbildung gilt sowieso nur als eine graphische Darstellung, die nicht verbindlich als technische Daten zu betrachten ist.
 Ici Vous verrez une image du produit pas emballé. Cette image devra être considérée seulement comme une représentation graphique pas liée aux caractéristiques techniques du produit.
 В данной графе приводится изображение изделия без упаковки; уточняем, что данный рисунок является условным изображением, не связанным с техническими характеристиками изделия.

② **Codice prodotto - Item code - Kode Artikel - Code produit - Код артикул**

●(A) Il codice articolo è composto da 12 caratteri alfanumerici e deve essere utilizzato per meglio indicare il materiale da ordinare.
 The item code is composed of 12 alphanumeric types and should be used to mark the ordered material.
 Der Artikelcode besteht aus 12 alphanumerischen Schriftzeichen und muss zur genauen Beschreibung der bestellten Produkten benutzt werden.
 Le code article est composé par 12 caractères alfa-numériques et doit être utilisé pour mieux indiquer le matériel qu'on désire acheter.
 Код артикула состоит из 12 знаков и используется для наилучшего указания изделия в заказе.

●(B) Le due cifre inserite in questa posizione indicano la tipologia di finitura del prodotto.
 The two digits in this position stand for the type of finish.
 Die zwei Zahlen auf dieser Stelle kennzeichnen die Ausführung des Artikels.
 Les deux chiffres qui se trouvent ici indiquent la finition de l'article.
 Две цифры в данном расположении указывают тип отделки изделия.

③ **Misure prodotto - Item sizes- Maß artikel - Mesure produit - Размеры артикула**

④ **Peso prodotto - Item weight - Gewicht des Artikels - Poids produit - Вес артикула**

In questa casella è indicato il peso del prodotto non imballato espresso in chilogrammi.
 This box indicates the weight of an unpacked item in kilograms.
 Auf diesem Kästchen steht das Gewicht eines unverpackten Artikels in Kg.
 Dans cette boîte est indiqué le poids du produit déballé en Kilos.
 В этой графе указан вес артикула, выраженный в кг. без упаковки.

⑤ **Portata prodotto - Capacity - Tragfähigkeit - Portée du produit - Максимальная нагрузка**

Espressa in Kg. essa si riferisce al peso massimo sopportabile ed equamente distribuito. La portata del prodotto è da ritenersi comunque indicativa e non vincolante per Arthemagroup, che non si assume alcuna responsabilità circa il non corretto utilizzo del prodotto venduto.
 The capacity, indicated in kilograms, refers to the maximum weight evenly distributed that an item can accommodate. The stated capacity is indicative and non-binding for Arthemagroup, which shall not be held responsible for any damage resulting from an improper use of any sold item.
 Die Tragfähigkeit – hier in Kilogram – bezieht sich auf das maximale, gleich verteilte Gewicht, dass ein Artikel tragen kann. Die Tragfähigkeit versteht sich als eine nicht verbindliche Richtangabe und Arthemagroup haftet nicht für Schaden, die bei einer unrichtigen Benutzung des verkauften Produkts entstehen.
 La portée du produit est indiquée en kilos. Elle se réfère au poids maximum et distribué en parts égales que le produit peut soutenir. Elle est toutefois approximative et pas contraignante pour Arthemagroup qui n'a aucune responsabilité sur l'usage pas correct du produit une fois il est vendu.
 Выраженная в кг, обозначает максимальный вес равномерно распределенного товара. Просьба учесть тот факт, что этот показатель довольно относительная величина и Arthemagroup не берет на себя никакой ответственности за некорректное использование проданного материала.

⑥ **Uso prodotto - Usage of the product - Benutzung des Produkts - Usage du produit - Использование продукции**

In questa casella è indicato il corretto uso del prodotto sul sistema di riferimento.
 This box explains how to use correctly the product on its system.
 Auf diesem Kästchen steht die korrekte Benutzung des Produkts auf das System.
 Dans cette boîte est indiqué l'usage correct du produit sur le système dont il fait partie.
 В этой графе приведены советы о правильном использовании соответствующих систем.

⑦ **Descrizione tecnica del prodotto - Technical description of the item - Technische Daten des Artikels - Description technique de l'article - Техническое описание артикула**

In questa casella è riportato il TYPE del prodotto ed anche una breve DESCRIZIONE dello stesso. Occasionalmente è possibile trovare anche la dicitura "F.S." seguita da un numero/signa che rappresenta la sola finitura di serie per quel type.
 Here you can find the Type of the item and a brief description of it. Occasionally it's possible to find the inscription "S.F" as well followed by a number/mark representing the only standard finishing for that type.
 Auf diesem Kästchen wird der Artikeltyp mit dessen kurzer Beschreibung eingeführt. Eventuell erscheint die Abkürzung "S.F." auch vor einer Anzahl/Kennwort. Diese Anzahl stellt die einzige Standardausführung für diesen Typ dar.
 Ici Vous trouverez le TYPE du produit et aussi une brève description du même. De temps en temps il est possible de trouver la forme "F.S." aussi, suivie d'un nombre/signa qui représente la seule finition de série pour ce type-là.
 В данной графе указывается ТИП артикула, а также его краткое описание. Иногда можно увидеть надпись "С.О.", за которой следуют другие сокращения, которые означают единственные возможные серийные отделки для данного типа.

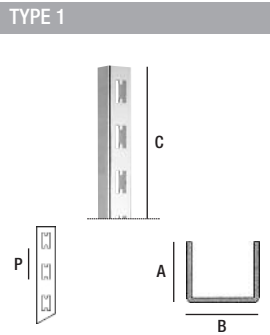
TYPE 1	COD.	A (mm)	B (mm)	C (mm)	P (mm)	KG
	GL0101--0000	25	30	2395	50	2,375

Colonna a "U" – asola singola sagomata.
"U" shaped column–single shaped slot.
"U" förmige Säule–modellierte einzelne Öse.
Colonne à crémaillère à "U" – trou simple modelé.
Колонна "U"-образная с одиночной фигурной перфорацией.
P: passo/pitch/Teilung/empattement/шар

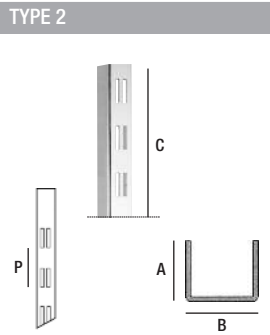
TYPE 2	COD.	A (mm)	B (mm)	C (mm)	P (mm)	KG
	GL0201--0000	25	30	2395	50	2,440

Colonna a "U" – asola doppia.
"U" shaped column double slot.
"U" förmige Säule Doppelöse.
Colonne à crémaillère à "U" – perforation double.
Колонна "U"-образная с двойной перфорацией.
P: passo/pitch/Teilung/empattement/шар

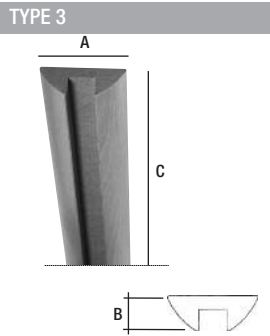
TYPE 3	COD.	A (mm)	B (mm)	C (mm)	KG
	GL0301--0000	100	40	2395	3,8

Profilo in legno stondato per type 1–2.
Rounded wooden profile for type 1–2.
Abgerundetes Holzprofil für Typ 1–2.
Profil en bois arrondi pour type 1–2.
Деревянный закругленный профиль для типа 1–2.

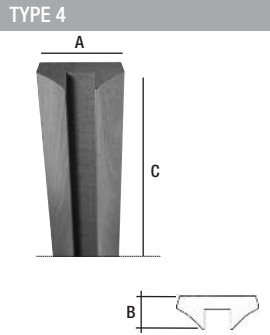
TYPE 4	COD.	A (mm)	B (mm)	C (mm)	KG
	GL0401--0000	100	40	2395	3,78

Profilo in legno sagomato per type 1–2.
Shaped wooden profile for type 1–2.
Modelliertes Holzprofil für Typ 1–2.
Profil en bois modelé pour type 1–2.
Деревянный профиль для типа 1–2.

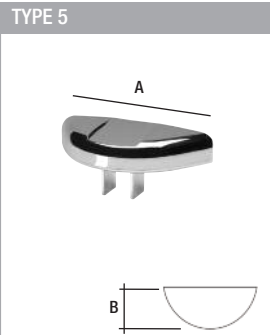
TYPE 5	COD.	A (mm)	B (mm)	KG
	GL0501--0000	120	52	0,035

Decorazione superiore stondata in plastica per type 3.
Upper plastic rounded decoration for type 3.
Obere abgerundete Plastikdekoration für Typ 3.
Décoration supérieure arrondie en plastique pour type 3.
Декоративный элемент для типа 3.

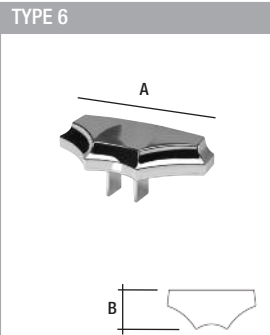
TYPE 6	COD.	A (mm)	B (mm)	KG
	GL0601--0000	120	52	0,039

Decorazione superiore sagomata in plastica per type 4.
Upper plastic shaped decoration for type 4.
Obere modellierte Plastikdekoration für Typ 4.
Décoration supérieure en plastique modelée pour type 4.
Декоративный фигурный элемент для типа 4.

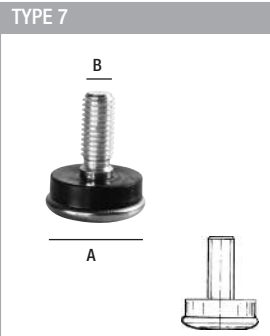
TYPE 7	COD.	A (mm)	B (mm)	KG
	GL0701--0000	Ø30	M10	0,028

Piedino regolabile.
Adjustable foot.
Verstellbarer Fuß.
Pied réglable.
Регулируемая ножка.

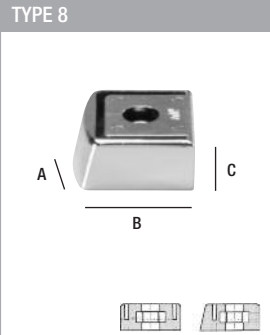
TYPE 8	COD.	A (mm)	B (mm)	C (mm)	KG
	GL0801--0000	35	35	15	0,020

Piedino in plastica/decorazione superiore per colonna a "U".
Plastic foot/upper decoration for "U" shaped column.
Fuß aus Plastik/obere Dekoration für "U" förmige Säule.
Pied en plastique/décoration supérieure pour colonne à crémaillère à "U".
Ножка пластиковая/Декоративная заглушка для "U"-образной колонны.

TYPE 9	COD.	A (mm)	B (mm)	P (mm)	KG
	GL0901--0000	460	2395	50	5,750
	<p>Colonna a "L" – asola singola sagomata. "L" shaped column–single shaped slot. "L" förmige Säule–modellerte einzelne Öse. Colonne à "L" – trou simple modelé. Колонна "L"-образная с одиночной фигурной перфорацией.</p> <p>P: passo/pitch/Teilung/empattement/шар</p>				

TYPE 13	COD.	A (mm)	B (mm)	C (mm)	KG
	GL1301--0000	581	12	2345	12,1
	GL1301--0000	881	12	2345	18,35
<p>Pannello di fondo in legno (in luce). Wooden back panel (between uprights). Holzrückwand (zwischen den Säulen). Panneau de fond en bois (entre les montants). Панель задняя деревянная (устанавливающаяся между колоннами).</p>					

TYPE 10	COD.	A (mm)	B (mm)	P (mm)	KG
	GL1001--0000	870	1495	50	5,6
	<p>Spalla a "T" per gondola–asola singola sagomata. "T" column for gondola–single shaped slot. "T" förmige Säule für Gondola–modellerte einzelne Öse. Montant à "T" pour gondole–trou simple modelé. Колонна "T"-образная с одиночной фигурной перфорацией.</p> <p>P: passo/pitch/Teilung/empattement/шар</p>				

TYPE 14	COD.	A (mm)	B (mm)	C (mm)	KG
	GL1401--0000	75	35	35	0,060
	<p>Supporto per type 12 con type 11 per pannello sovrapposto. Support for type 12 with type 11 for panel laid upon the column. Träger für Typ 12 mit Typ 11 für Paneele über den Säulen liegend. Support pour type 12 avec type 11 pour panneau superposés à la colonne. Держатель типа 11 для панели типа 12.</p>				

TYPE 11	COD.	A (mm)	KG
	GL1101--0000	582	1,170
	GL1102--0000	882	1,720
<p>Barra di collegamento. Connecting bar. Verbindungsstange. Barre de jonction. Соединительная перекладина.</p>			

TYPE 15	COD.	A (mm)	B (mm)	C (mm)	KG
	GL1501--0000	75	35	19	0,055
	<p>Supporto per type 13 con type 11 per pannello in luce. Support for type 13 with type 11 for panel placed between the columns. Träger für Typ 13 mit Typ 11 für Paneele zwischen den Säulen liegend. Support pour type 13 avec type 11 pour panneau entre les colonnes. Держатель типа 11 для панели типа 13.</p>				

TYPE 12	COD.	A (mm)	B (mm)	C (mm)	KG
	GL1201--0000	597	12	2345	12,45
	GL1202--0000	897	12	2345	18,8
<p>Pannello di fondo in legno (sovrapposto). Wooden back panel (laid upon). Holzrückwand (über die Säulen liegend). Panneau de fond en bois (superposé). Панель задняя деревянная (закрывающая часть колонны).</p>					

TYPE 16	COD.	A (mm)	KG
	GL1601--0000	∅ 34	0,006
	<p>Elemento fissaggio per pannelli in legno sp. 3–8–12–16–18 (sovrapposti). Fixing element for wooden panels th. 3–8–12–16–18 laid upon. Paneelsbefestigung für Paneele D. 3–8–12–16–18 über den Säulen liegend. Fixation pour panneaux en bois ép. 3–8–12–16–18 superposés aux colonnes. Фиксирующий элемент для деревянной панели (закрывающей часть колонны).</p>		

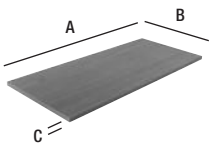
TYPE 17	COD.	A (mm)	B (mm)	C (mm)	KG	📦
	GL1701--0000	579	410	18	3,1	30
	GL1702--0000	879	410	18	4,6	25

Ripiano di base in legno.
Base wooden shelf.
Holzfussfach.
Étagère de base en bois.
Полка нижняя деревянная.

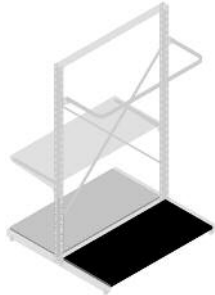

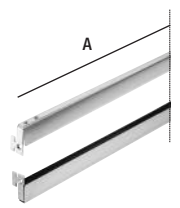
TYPE 21	COD.	A (mm)	KG
	GL2101--0000	600	0,580
	GL2102--0000	900	0,840

Coppia canaline di supporto per pannello sovrapposto type 12.
Pair of guidelines for panel support type 12.
Paar Führungen für Panelträger Typ 12.
Couple guides pour support panneau type 12.
Пара направляющих для панели типа 12.

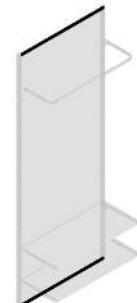

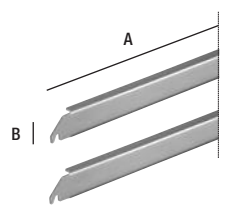
TYPE 18	COD.	A (mm)	B (mm)	KG
	GL1801--0000	580	18	0,4
	GL1802--0000	880	18	0,6

Coppia canaline per supporto pannelli di fondo in luce. Type 13 con type 20.
Pair of guidelines for back panels placed between the columns. Type 13 with type 20.
Paar Führungen für Rückpaneele zwischen den Säulen. Typ 13 mit Typ 20.
Couple guides pour panneaux de fond placés entre les colonnes. Type 13 avec type 20.
Пара направляющих для типа 13 с типом 20.

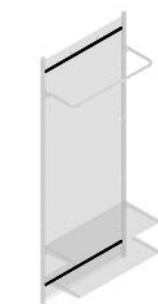

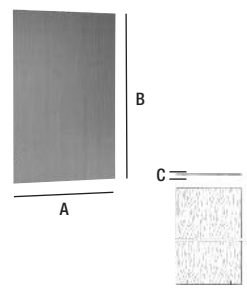
TYPE 22	COD.	A (mm)	B (mm)	C (mm)	KG
	GL2201--0000	881	1425	18	16,3
	GL2202--0000	581	1425	18	10,75

Pannello in legno per gondola.
Wooden panel for gondola.
Panneel für Gondola.
Panneau en bois pour gondole.
Панель деревянная для гондолы.

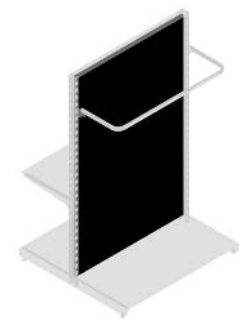

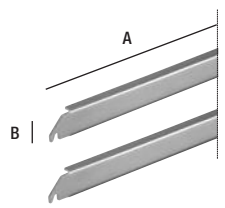
TYPE 19	COD.	A (mm)	B (mm)	KG
	GL1901--0000	580	18	0,4
	GL1902--0000	880	18	0,6

Coppia canaline per supporto ripiano di base type 17.
Pair of guidelines supporting base shelf type 17.
Paar Führungen für Holzfussfachträger Typ 17.
Couple guides/supports étagère de base type 17.
Пара направляющих для нижней полки типа 17.

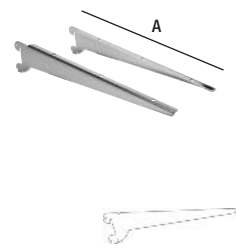

TYPE 23	COD.	A (mm)	KG
	GL2301--0000	300	0,520
	GL2302--0000	400	0,680

Coppia mensole per ripiano in legno.
Pair of brackets for wooden shelf.
Trägerpaar für Holzfach.
Couple supports pour étagère en bois.
Пара держателей для деревянной полки.

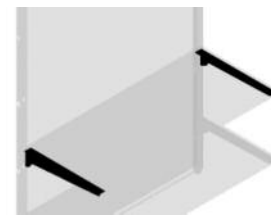

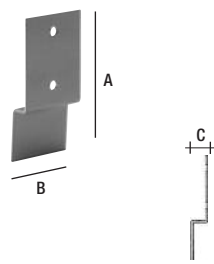
TYPE 20	COD.	A (mm)	B (mm)	C (mm)	KG
	GL2001--0000	70	35	10,5	0,033

Supporto per pannello di fondo in luce type 13 con type 18.
Support for panel placed between the columns type 13 for type 18.
Träger für Paneel zwischen den Säulen Typ 13 und Typ 18.
Support pour panneau entre les colonnes type 13 pour type 18.
Держатель задней панели типа 13 с типом 18.

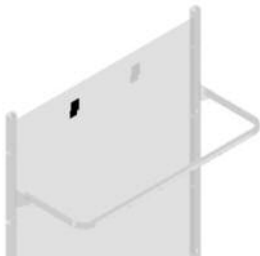

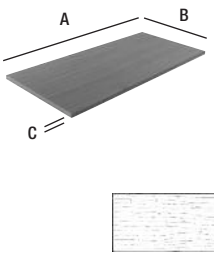
TYPE 24	COD.	A (mm)	B (mm)	C (mm)	KG	📦
	GL2401--0000	600	400	18	3	30
	GL2402--0000	900	400	18	4,5	25

Ripiano in legno.
Wooden shelf.
Holzfach.
Étagère en bois.
Полка деревянная.



TYPE 25	COD.	A (mm)	B (mm)	C (mm)	KG	📦
	GL2501--0000	600	400	25	4,16	40
	GL2502--0000	900	400	25	6,25	35
	GL2503--0000	1200	400	25	8,34	30

Ripiano in legno sofformato.
Sofforming wooden shelf.
Sofforming Holzfach.
Étagère en bois sofforming.
Полка деревянная с закругленным бортиком.

TYPE 29	COD.	A (mm)	B (mm)	KG	📦
	GL2901--0000	300	Ø440	1,17	8

Braccio appenderia girevole per barra appenderia.
Rotating hanging arm for hanging bar.
Drehbarer Abhängearm für Hängestange.
Bras d'accrochage tournant pour barre d'accrochage.
Кронштейн-карусель с креплением к овальной перекладине.

TYPE 26	COD.	A (mm)	KG	📦
	GL2601--0000	100	0,080	2
	GL2602--0000	150	0,090	2
	GL2603--0000	250	0,110	2

Barretta per barra appenderia.
Hook for hanging bar.
Aufhängehaken für Hängestange.
Tige pour barre d'accrochage.
Кронштейн с креплением к овальной перекладине.

TYPE 30	COD.	A (mm)	KG	📦
	GL3001--0000	300	0,27	10
	GL3002--0000	400	0,36	10

Barra diritta per barra appenderia.
Straight bar for hanging bar.
Gerade Stange für Hängestange.
Barre droite pour barre d'accrochage.
Прямой кронштейн с креплением к овальной перекладине.

TYPE 27	COD.	A (mm)	KG	📦
	GL2701--0000	200	0,130	2
	GL2702--0000	300	0,150	2

Barretta portablisters semplice per barra appenderia.
Hook blister-holder for hanging bar.
Einfacher Aufhängehaken für Blister-Packungen für Hängestange.
Tige porte-blisters simple pour barre d'accrochage.
Кронштейн для блистеров с креплением к овальной перекладине.

TYPE 31	COD.	A (mm)	KG	📦
GL3101--0000	360	0,34	10	

Barra inclinata con ganci per barra appenderia.
Slanted bar with hooks for hanging bar.
Schräge Stange mit Haken für Hängestange.
Barre inclinée avec crochets pour barre d'accrochage.
Наклонный кронштейн с крючками с креплением к овальной перекладине.

TYPE 28	COD.	A (mm)	KG	📦
	GL2801--0000	200	0,16	2
	GL2802--0000	300	0,19	2

Barretta portablisters doppia per barra appenderia.
Double hook blister-holder for hanging bar.
Doppelter Aufhängehaken für Blister-Packungen für Hängestange.
Tige porte-blisters double pour barre d'accrochage.
Кронштейн двойной для блистера с креплением к овальной перекладине.

TYPE 32	COD.	A (mm)	KG	📦
GL3201--0000	360	0,32	10	
GL3202--0000	400	0,36	10	

Barra inclinata per barra appenderia.
Slanted bar for hanging bar.
Schräge Stange für Hängestange.
Barre inclinée pour barre d'accrochage.
Наклонный кронштейн с креплением к овальной перекладине.

TYPE 33	COD.	A (mm)	B (mm)	KG	📦
	GL3301--0000	325	125	0,35	10
	GL3302--0000	400	125	0,4	10

Barra a gradino per barra appenderia.
Step-shaped bar for hanging bar.
Stufenförmige Stange für Hängestange.
Barre à marche pour barre d'accrochage.
Ступенчатый кронштейн с креплением к овальной перекладине.

TYPE 37	COD.	A (mm)	KG	📦
	GL3701--0000	300	0,14	2

Barretta a 3 gradini per barra appenderia.
3-step hook for hanging bar.
3-Stufen-Aufhängehaken für Hängestange.
Tige à 3 marches pour barre d'accrochage.
3-х-ступенчатый крючок с креплением к овальной перекладине.

TYPE 34	COD.	A (mm)	B (mm)	KG	📦
	GL3401--0000	360	250	0,55	10

Barraalzata inclinata per barra appenderia.
Slanted raised bar for hanging bar.
Schräge erhöhte Stange für Hängestange.
Barre inclinée levée pour barre d'accrochage.
Наклонный кронштейн с креплением к овальной перекладине.

TYPE 38	COD.	A (mm)	B (mm)	KG	📦
	GL3801--0000	600	350	0,89	40
	GL3802--0000	900	350	1,32	35

Barra appenderia staccata.
Face-out hanging bar.
Lose Hängestange.
Barre décalée.
Выступающее вешало.

TYPE 35	COD.	A (mm)	KG	📦
	GL3501--0000	100	0,045	2

Barretta per barra appenderia.
Hook for hanging bar.
Aufhängehaken für Hängestange.
Tige pour barre d'accrochage.
Крючок с креплением к овальной перекладине.

TYPE 39	COD.	A (mm)	B (mm)	KG	📦
	GL3901--0000	600	90	0,8	30
	GL3902--0000	900	90	1,05	25

Barra appenderia aderente.
Adherent hanging bar.
Gerade Hängestange.
Barre d'accrochage.
Прилегающее вешало.



TYPE 36	COD.	A (mm)	KG	📦
	GL3601--0000	200	0,085	2

Barretta a 2 gradini per barra appenderia.
2-step hook for hanging bar.
2-Stufen Aufhängehaken für Hängestange.
Tige à 2 marches pour barre d'accrochage.
2-х-ступенчатый крючок с креплением к овальной перекладине.

TYPE 40	COD.	A (mm)	B (mm)	C (mm)	KG
GL4001--0000	1500	750	800	19	

Telaio per tavolo.
Frame for counter.
Rahmen für Tisch.
Châssis pour table.
Каркас для стола.

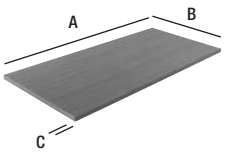
TYPE 41	COD.	A (mm)	B (mm)	C (mm)	KG
	GL4101--0000	1500	750	30	20

Ripiano in legno per tavolo.
Wooden shelf for counter.
Holzfach für Tisch.
Étagère en bois pour table.
Столешница.

TYPE 45	COD.	A (mm)	B (mm)	C (mm)	KG
	GL4501--0000	90	90	93	1,28

Set di piedini per cassetiera type 43.
Set of feet for drawer cabinet type 43.
Satz an Füße für Schublade Typ 43.
Set de pieds pour meuble à tiroirs type 43.
Набор ножек для комода типа 43.

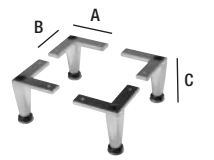
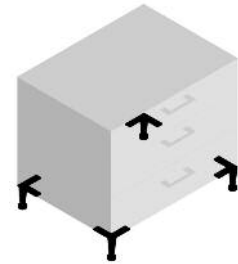
TYPE 42	COD.	A (mm)	B (mm)	C (mm)	KG
	GL4201--0000	600	450	300	17
	GL4202--0000	900	450	300	25,5

Cassetiera in legno per tavolo con un vano ed un cassetto.
Wooden drawer cabinet with one opening and one drawer.
Holzkommode mit einem Raum und einer Schublade.
Meuble à tiroirs en bois avec un espace et un tiroir.
Структура с ящиком и нишей для стола.

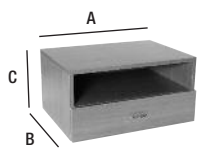
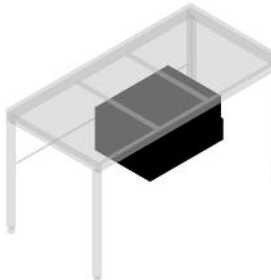
TYPE 46	COD.	A (mm)	B (mm)	C (mm)	KG
	GL4601--0000	900	210	900	36

Box portacravatte.
Ties-holder.
Krawattenträger.
Porte-cravates.
Бокс для галстуков.

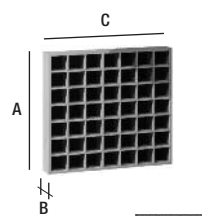
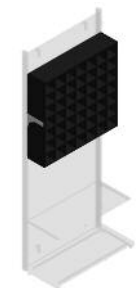
TYPE 43	COD.	A (mm)	B (mm)	C (mm)	KG
	GL4301--0000	600	450	450	30
	GL4302--0000	900	450	450	35

Cassetiera in legno.
Wooden drawers cabinet.
Holzschublade.
Tiroirs en bois.
Комод деревянный.

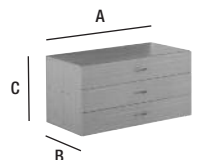
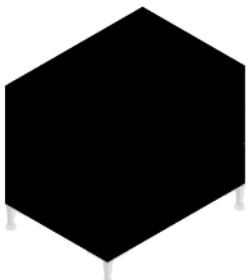
TYPE 47	COD.	A (mm)	B (mm)	KG
	GL4701--0000	550	695	0,18

Coppia supporti regolabili per cassetiera type 42.
Adjustable shelving twins for cabinet type 42.
Verstellbares Trägerpaar für Schublade Typ 42.
Couple supports réglables pour tiroirs type 42.
Пара регулируемых держателей для комода типа 42.

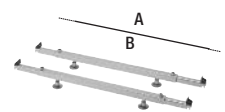
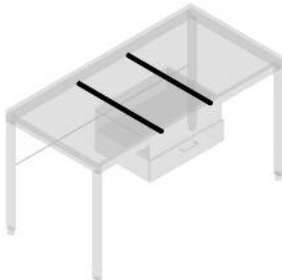
TYPE 44	COD.	A (mm)	KG
	GL4401--0000	215	0,5



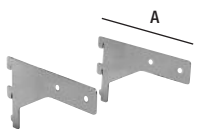
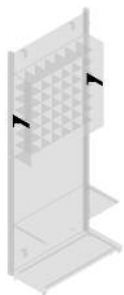

Coppia mensole per box cravatte.
Shelving twins for ties holder.
Trägerpaar für Krawattenträger.
Couple supports pour porte-cravates.
Пара держателей боксов для галстуков.

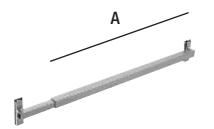
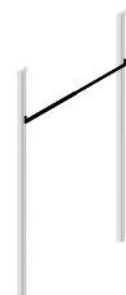

TYPE 48	COD.	A (mm)	KG
	GL4801--0000	705	1,8

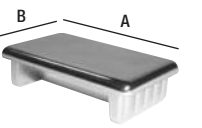



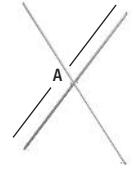
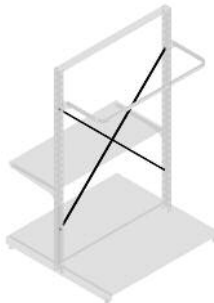

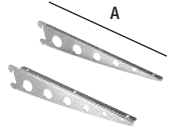
Dima regolabile per montaggio strutture Global.
Adjustable template for assembling of Global structure.
Verstellbares Schablone zur Montage.
Moule réglable pour assemblage structures Global.
Регулируемый шаблон для монтажа структур Global.

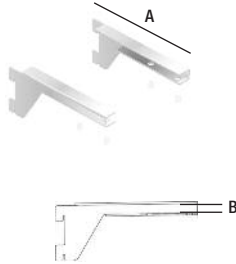

TYPE 49	COD.	A (mm)	B (mm)	KG
	GL4901--0000	50	30	0,010
	<p>Copriresta per colonna. Head cover for column. Kappe für Säule. Bouchon pour colonne. Заглушка для колонны.</p>			

TYPE 54	COD.	A (mm)	KG
	GL5401--0000	1267	1,02
	<p>Coppia tiranti per spalla a "T" gondola. Side tie-beams pair for gondola. Zugstangenpaar für Gondola. Couple tirants pour gondole. Пара распорок для гондолы.</p>		

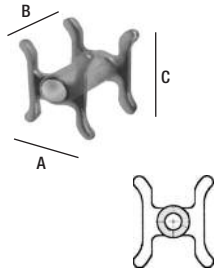
TYPE 50	COD.	A (mm)	KG
	GL5001--0000	350	0,76
	<p>Coppia mensole forate per ripiano in legno. Pair of pierced brackets for wooden shelf. Trägerpaar mit Löchern für Holzfach. Couple supports perforés pour étagère en bois. Пара полкодержателей с отверстиями для типа.</p>		

TYPE 55	COD.	A (mm)	B (mm)	KG
	GL5501--0000	180	12	0,375
	<p>Coppia mensole per ripiani sp.8-10 mm. Pair of brackets for shelves th. 8-10 mm. Trägerpaar für Fächer D. 8-10 mm. Couple supports pour étagères épaisseur 8-10 mm. Пара держателей для полок толщ. 8-10 мм.</p>			

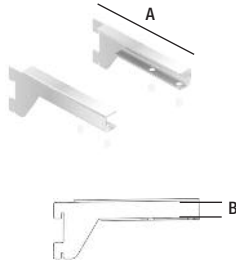
TYPE 52	COD.	A (mm)	B (mm)	C (mm)	KG
	GL5201--0000	26	21	30	0,002
	<p>Inserto per fissaggio a parete colonna a "U" Type 1-2. Insert for "U" column type 1-2 wall fixing. Einsatz zur Wandbefestigung von "U" Säulen Typ 1-2. BInsert pour fixation au mur colonne à "U" Type 1-2. Вставка фиксирующая "U"-образную колонну типа 1-2 к стене.</p>				

TYPE 56	COD.	A (mm)	B (mm)	KG
	GL5601--0000	180	21	0,415
	<p>Coppia mensole per ripiani sp.18-20 mm. Pair of brackets for shelves th. 18-20 mm. Trägerpaar für Fächer D. 18-20 mm. Couple supports pour étagères épaisseur 18-20 mm. Пара держателей для полок толщ. 18-20 мм.</p>			

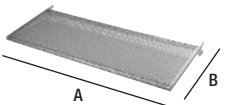
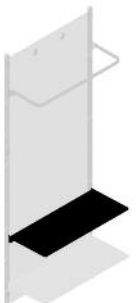
TYPE 53	COD.	A (mm)	B (mm)	KG	h
	GL5301--0000	600	400	2,28	30
	GL5302--0000	900	400	2,99	30
	<p>Ripiano in lamiera forata con mensole. Pierced sheet shelf with brackets. Fach aus Lochblech mit Trägern. Étagère en tôle perforée avec supports. Металлическая полка с отверстиями.</p>				

STRUTTURA A PARETE WALL STRUCTURE

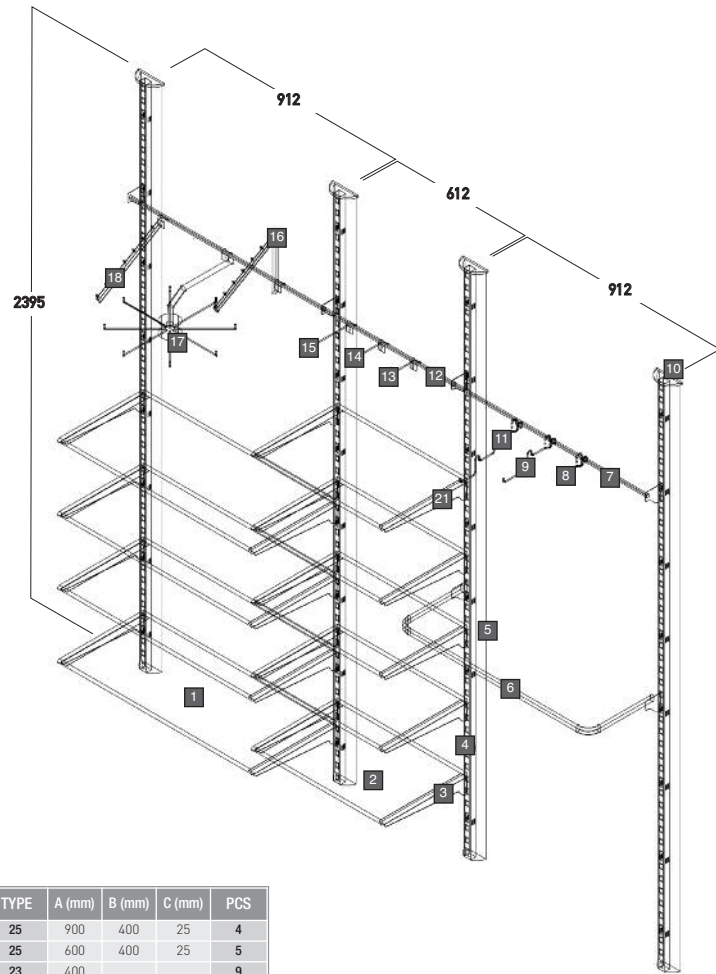

POS	SYSTEM	TYPE	A (mm)	B (mm)	C (mm)	PCS
1	GLOBAL	25	900	400	25	4
2	GLOBAL	25	600	400	25	5
3	GLOBAL	23	400			9
4	GLOBAL	1	25	30	2375	4
5	GLOBAL	3	100	40	2395	4
6	GLOBAL	38	900	350		1
7	GLOBAL	39	900	90		2
8	GLOBAL	35	100			1
9	GLOBAL	36	200			1
10	GLOBAL	5	120	52		4
11	GLOBAL	37	300			1
12	GLOBAL	39	600	90		1
13	GLOBAL	26	100			1
14	GLOBAL	26	150			1
15	GLOBAL	26	250			1
16	GLOBAL	34	360	250		1
17	GLOBAL	29	300	Ø440		1
18	GLOBAL	32	360			1

GONDOLA GONDOLA

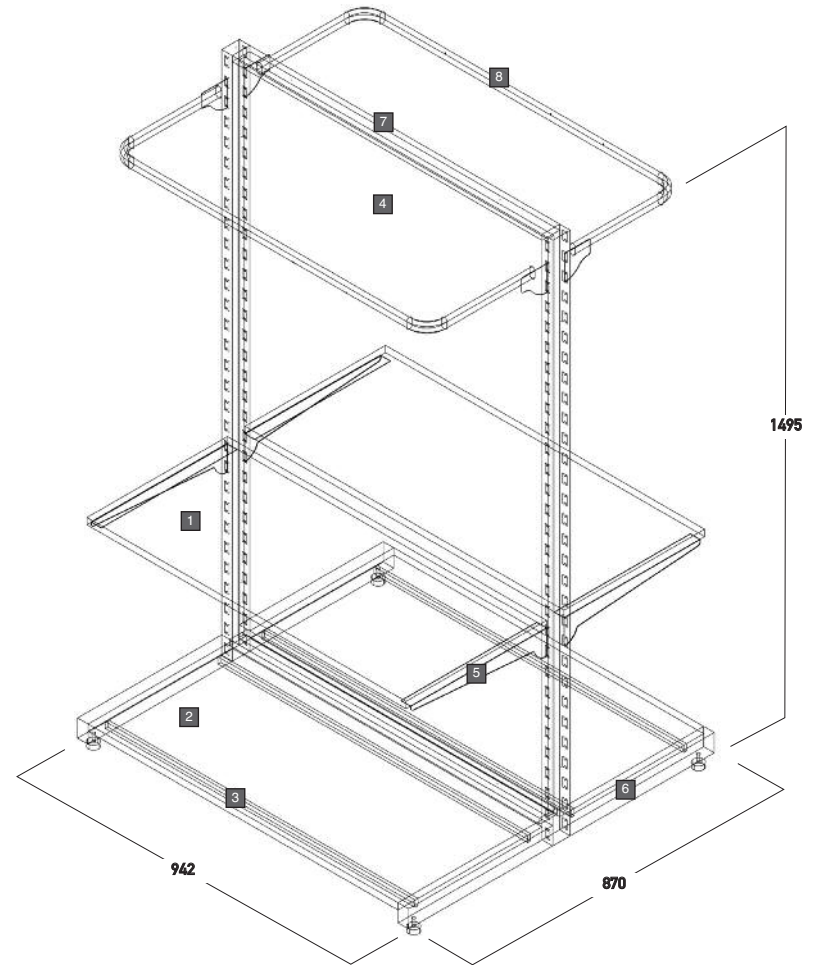

POS	SYSTEM	TYPE	A (mm)	B (mm)	C (mm)	PCS
1	GLOBAL	24	900	400	18	2
2	GLOBAL	17	879	410	18	2
3	GLOBAL	19	880	18		2
4	GLOBAL	22	881	1425		1
5	GLOBAL	23	400			2
6	GLOBAL	10	870	1495		2
7	GLOBAL	11	882			2
8	GLOBAL	38	900	350		2

MONTAGGIO DI PANNELLI FRESATI A PARETE FIXING OF SLATTED PANELS TO THE WALL

Applicazione su colonne a "L"
Application on "L" columns

Applicazione su colonne a "U"
Application on "U" columns

MONTAGGIO A PARETE DEI PANNELLI DI FONDO FIXING OF BACK PANELS TO THE WALL

Sol. 1 o 2

I pannelli possono essere posizionati con due diversi criteri:
1 - Sovrapposti alla colonna
2 - In luce tra le colonne

Panels can be placed according to two different methods:
1 - Laid upon the column
2 - Cut in exact dimensions between the columns

artheta[®]
IIII GROUP

ARTHEMAGROUP s.r.l.

Via Cascina Restelli, 5 - 20040 Aicurzio (MI) Italy
Tel. +39 0396093099 - Fax +39 0396093307
arthemagroup@arthemagroup.it - www.arthemagroup.it

PATENTED[®]