

arthema[®]
SYSTEM
Catalogo Tecnico 2009 .1

Gentile Cliente, per una facile lettura del catalogo, Vi invitiamo a consultare questa legenda.
 Dear Customer, please read the following guidelines for a better understanding of our catalogue.
 Sehr geehrter Kunde, bitte lesen Sie die folgenden Zeichenerklärungen für ein besseres Verständnis unseres Katalogs.
 Cher client, pour simplifier la lecture du catalogue, Vous pouvez consulter cette légende.
 Уважаемый клиент, для лучшего понимания Каталога предлагаем Вам прочесть данное толкование.

TYPE 20	COD.	A (mm)	B (mm)	KG	Capacity
	AL2001--0000	600	350	0,89	40
	AL2002--0000	900	350	1,32	35

7 Barra appenderia staccata.
 Outfstanding hanging bar.
 Lose Abhängestange.
 Barre d'accrochage décalée.
 Выступающее вешало.

1 **Immagine prodotto - Item picture - Abbildung artikel - Image produit - Изображение артикула**

In questa casella è riportata un'immagine indicativa del prodotto non imballato; si precisa che tale immagine è da considerarsi come una rappresentazione grafica non vincolante ai fini delle caratteristiche tecniche del prodotto.
 This box contains a picture of the unpacked article. This picture is just as an indication, and it is therefore meant as a graphic representation, which is not as worth as a technical report.
 Auf diesem Kästchen steht eine Abbildung des unverpackten Artikels. Diese Abbildung gilt sowieso nur als eine graphische Darstellung, die nicht verbindlich als technische Daten zu betrachten ist.
 Ici Vous verrez une image du produit pas emballé. Cette image devra être considérée seulement comme une représentation graphique pas liée aux caractéristiques techniques du produit.
 В данной графе приводится изображение изделия без упаковки; уточняем, что данный рисунок является условным изображением, не связанным с техническими характеристиками изделия.

2 **Codice prodotto - Item code - Kode Artikel - Code produit - Код артикул**

●(A) Il codice articolo è composto da 12 caratteri alfanumerici e deve essere utilizzato per meglio indicare il materiale da ordinare.
 The item code is composed of 12 alphanumeric types and should be used to mark the ordered material.
 Der Artikelcode besteht aus 12 alphanumerischen Schriftzeichen und muss zur genauen Beschreibung der bestellten Produkten benutzt werden.
 Le code article est composé par 12 caractères alfa-numériques et doit être utilisé pour mieux indiquer le matériel qu'on désire acheter.
 Код артикула состоит из 12 знаков и используется для наилучшего указания изделия в заказе.

●(B) Le due cifre inserite in questa posizione indicano la tipologia di finitura del prodotto.
 The two digits in this position stand for the type of finish.
 Die zwei Anzahlen auf dieser Stelle kennzeichnen die Ausführung des Artikels.
 Les deux chiffres qui se trouvent ici indiquent la finition de l'article.
 Две цифры в данном расположении указывают тип отделки изделия.

3 **Misure prodotto - Item sizes- Maß artikel - Mesure produit - Размеры артикула**

4 **Peso prodotto - Item weight - Gewicht des Artikels - Poids produit - Вес артикула**

In questa casella è indicato il peso del prodotto non imballato espresso in chilogrammi.
 This box indicates the weight of an unpacked item in kilograms.
 Auf diesem Kästchen steht das Gewicht eines unverpackten Artikels in Kilos.
 Dans cette boîte est indiqué le poids du produit déballé en Kilos.
 В этой графе указан вес артикула, выраженный в кг. без упаковки.

5 **Portata prodotto - Capacity - Tragfähigkeit - Portée du produit - Максимальная нагрузка**

Espressa in Kg. essa si riferisce al peso massimo sopportabile ed equamente distribuito. La portata del prodotto è da ritenersi comunque indicativa e non vincolante per Arthemagroup, che non si assume alcuna responsabilità circa il non corretto utilizzo del prodotto venduto.
 The capacity, indicated in kilograms, refers to the maximum weight evenly distributed that an item can accommodate. The stated capacity is indicative and non-binding for Arthemagroup, which shall not be held responsible for any damage resulting from an improper use of any sold item.
 Die Tragfähigkeit – hier in Kilogramm – bezieht sich auf das maximale, gleich verteilte Gewicht, dass ein Artikel tragen kann. Die Tragfähigkeit versteht sich als eine nicht verbindliche Richtangabe und Arthemagroup haftet nicht für Schaden, die bei einer unrichtigen Benutzung des verkauften Produkts entstehen.
 La portée du produit est indiquée en kilos. Elle se réfère au poids maximum et distribué en parts égales que le produit peut soutenir. Elle est toutefois approximative et pas contraignante pour Arthemagroup qui n'a aucune responsabilité sur l'usage pas correct du produit une fois il est vendu.
 Выраженная в кг, обозначает максимальный вес равномерно распределенного товара. Просьба учесть тот факт, что этот показатель довольно относительная величина и Arthemagroup не берет на себя никакой ответственности за некорректное использование проданного материала.

6 **Uso prodotto - Usage of the product - Benutzung des Produkts - Usage du produit - Использование продукции**

In questa casella è indicato il corretto uso del prodotto sul sistema di riferimento.
 This box explains how to use correctly the product on its system.
 Auf diesem Kästchen steht die korrekte Benutzung des Produkts auf das System.
 Dans cette boîte est indiqué l'usage correct du produit sur le système dont il fait partie.
 В этой графе приведены советы о правильном использовании соответствующих систем.

7 **Descrizione tecnica del prodotto - Technical description of the item - Technische Daten des Artikels - Description technique de l'article - Техническое описание артикула**

In questa casella è riportato il TYPE del prodotto ed anche una breve DESCRIZIONE dello stesso. Occasionalmente è possibile trovare anche la dicitura "F.S." seguita da un numero/signa che rappresenta la sola finitura di serie per quel type.
 Here you can find the Type of the item and a brief description of it. Occasionally it's possible to find the inscription "S.F" as well followed by a number/mark representing the only standard finishing for that type.
 Auf diesem Kästchen wird der Artikeltyp mit dessen kurzer Beschreibung eingeführt. Eventuell erscheint die Abkürzung "S.F." auch vor einer Anzahl/Kennwort. Diese Anzahl stellt die einzige Standardausführung für diesen Typ dar.
 Ici Vous trouverez le TYPE du produit et aussi une brève description du même. De temps en temps il est possible de trouver la forme "F.S." aussi, suivie d'un nombre/signa qui représente la seule finition de série pour ce type-là.
 В данной графе указывается ТИП артикула, а также его краткое описание. Иногда можно увидеть надпись "С.О.", за которой следуют другие сокращения, которые означают единственные возможные серийные отделки для данного типа.

TYPE 1	COD.	A (mm)	P (mm)	KG
	AL0101--0000	1290	50	0,6
	AL0102--0000	2000	50	1,0
	AL0103--0000	2400	50	1,2

Profilo centrale in alluminio per pannello – asola singola.
 Central aluminium profile for panel – single slot.
 Zentralprofil aus Aluminium für Paneel – Einzellochung.
 Profil central en aluminium pour panneau – perforation unique.
 Центральный алюминиевый профиль для панели – с одиночной перфорацией.

P: passo/pitch/Teilung/empattement/шар

TYPE 5	COD.	A (mm)	B (mm)	C (mm)	P (mm)	KG
	AL0501--0000	595	2400	19	100	17,8
	AL0502--0000	895	2400	19	100	26,8

Pannello dogato.
 Slatted panel.
 Paneel mit Lamellen.
 Panneau rainuré.
 Экономпанель.

P: passo/pitch/Teilung/empattement/шар

TYPE 2	COD.	A (mm)	P (mm)	KG
	AL0201--0000	2400	50	0,9

Profilo laterale in alluminio per pannello – asola singola.
 Side aluminium profile for panel – single slot.
 Seitenprofil aus Aluminium für Paneel – Einzellochung.
 Profil latéral en aluminium pour panneau – perforation unique.
 Боковой алюминиевый профиль для панели – с одиночной перфорацией.

P: passo/pitch/Teilung/empattement/шар

TYPE 6	COD.	A (mm)	B (mm)	C (mm)	P (mm)	KG
	AL0601--0000	595	2400	19	150	17,8
	AL0602--0000	895	2400	19	150	26,8

Pannello dogato.
 Slatted panel.
 Paneel mit Lamellen.
 Panneau rainuré.
 Экономпанель.

P: passo/pitch/Teilung/empattement/шар

TYPE 3	COD.	A (mm)	P (mm)	KG
	AL0301--0000	2400	50	1,4

Profilo centrale in alluminio per pannello – asola doppia.
 Central aluminium profile for panel – double slot.
 Zentralprofil aus Aluminium für Paneel – Doppellochung.
 Profil central en aluminium pour panneau – perforation double.
 Центральный алюминиевый профиль для панели – с двойной перфорацией.

P: passo/pitch/Teilung/empattement/шар

TYPE 7	COD.	A (mm)	KG
	AL0701--0000	595	0,1
	AL0702--0000	895	0,1

Profilo in alluminio a "T" per type 5-6.
 Aluminium "T" profile for type 5-6.
 "T" Profil aus Aluminium für Typ 5-6.
 Profil à "T" en aluminium pour type 5-6.
 "T"-образный алюминиевый профиль для типа 5-6.

TYPE 4	COD.	A (mm)	B (mm)	C (mm)	L (mm)	KG
	AL0401--0000	1205	2400	19	602,5	36,0
	AL0402--0000	1205	2400	19	902,5	36,0

Pannello di fondo in legno con 2 fresature verticali.
 Wall wooden panel with 2 vertical slats.
 Wandpaneel aus Holz mit 2 senkrechten Fräsen.
 Panneau au mur en bois avec deux rainures verticales.
 Деревянная задняя панель с 2-мя вертикальными пазами.

TYPE 8	COD.	A (mm)	B (mm)	C (mm)	KG
	AL0801--0000	595	2400	19	17,8
	AL0802--0000	895	2400	19	26,8

Pannello di fondo in legno.
 Wooden back panel.
 Rückwandpaneel aus Holz.
 Panneau de fond en bois.
 Деревянная задняя панель.

TYPE 9	COD.	A (mm)	B (mm)	C (mm)	KG
	AL0901--0000	1052	760	1475	17,0

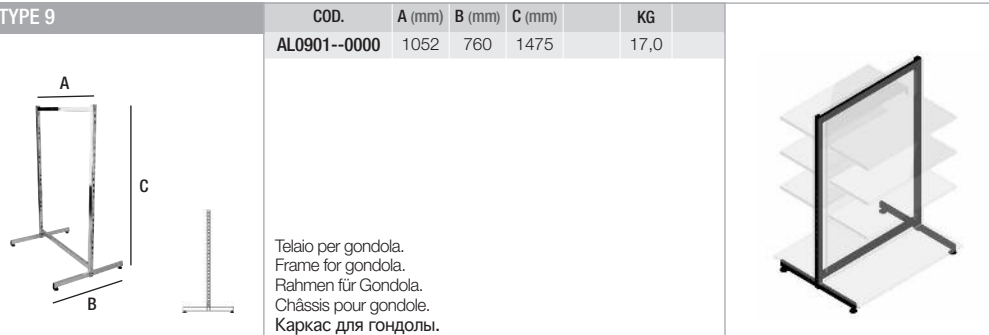

Telaio per gondola.
Frame for gondola.
Rahmen für Gondola.
Châssis pour gondole.
Каркас для гондолы.

TYPE 13	COD.	A (mm)	B (mm)	KG
	AL1301--0000	18,5	20	0,001



Supporto per pannello di fondo type 8. Terminale sinistro – asola singola.
Support for back panel type 8. Left terminal – single slot.
Träger für Wandpaneel Typ 8. Linke Verbindung – Einzelbohrung.
Support pour panneau de fond type 8. Terminal gauche – perforation unique.
Держатель задней панели типа 8. Левый терминал – для одиночной перфорации.

TYPE 10	COD.	A (mm)	B (mm)	C (mm)	L (mm)	KG
	AL1001--0000	1055	1425	19	902,5	18,8



Pannello per gondola in legno con 2 fresature verticali.
Wooden panel for gondola with 2 vertical slats.
Holzpaneel für Gondola mit 2 senkrechten Fräsen.
Panneau en bois pour gondole avec deux rainures verticales.
Деревянная панель гондолы с 2-мя вертикальными пазами.

TYPE 14	COD.	A (mm)	B (mm)	KG
	AL1401--0000	18,5	20	0,001



Supporto per pannello di fondo type 8. Terminale destro – asola singola.
Support for back panel type 8. Right terminal – single slot.
Träger für Wandpaneel Typ 8. Rechte Verbindung – Einzelbohrung.
Support pour panneau de fond type 8. Terminal droit – perforation unique.
Держатель задней панели типа 8. Правый терминал – для одиночной перфорации.

TYPE 11	COD.	A (mm)	B (mm)	C (mm)	KG
	AL1101--0000	1055	400	18	5,3

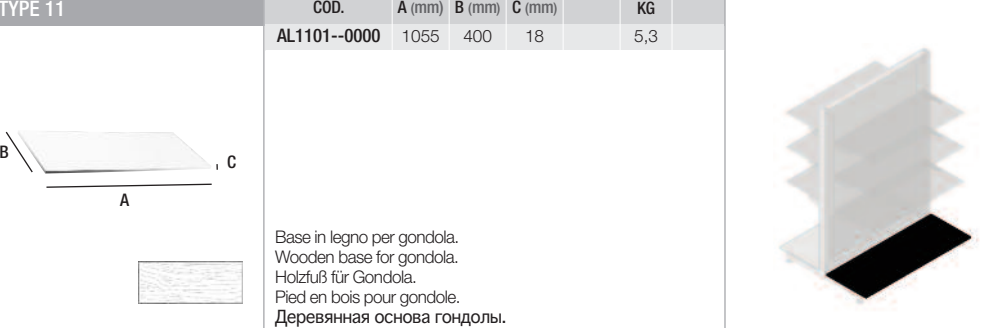

Base in legno per gondola.
Wooden base for gondola.
Holzfuß für Gondola.
Pied en bois pour gondole.
Деревянная основа гондолы.

TYPE 15	COD.	A (mm)	B (mm)	KG
	AL1501--0000	25	20	0,002

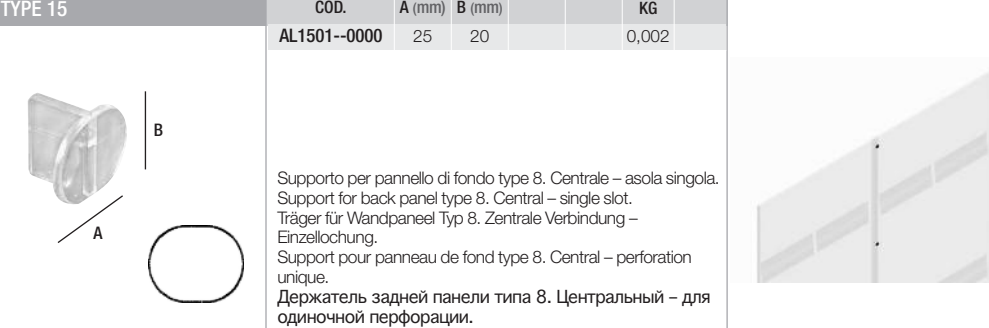

Supporto per pannello di fondo type 8. Centrale – asola singola.
Support for back panel type 8. Central – single slot.
Träger für Wandpaneel Typ 8. Zentrale Verbindung – Einzelbohrung.
Support pour panneau de fond type 8. Central – perforation unique.
Держатель задней панели типа 8. Центральный – для одиночной перфорации.

TYPE 12	COD.	A (mm)	KG
	AL1201--0000	400	0,4

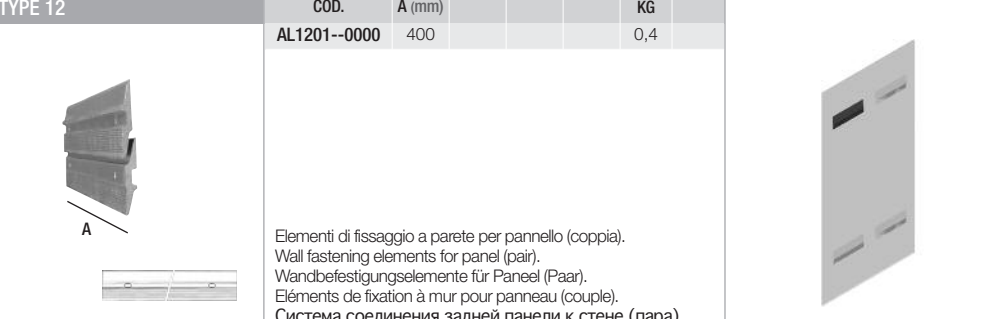

Elementi di fissaggio a parete per pannello (coppia).
Wall fastening elements for panel (pair).
Wandbefestigungselemente für Paneel (Paar).
Éléments de fixation à mur pour panneau (couple).
Система соединения задней панели к стене (пара).

TYPE 16	COD.	A (mm)	B (mm)	KG
	AL1601--0000	35	20	0,002

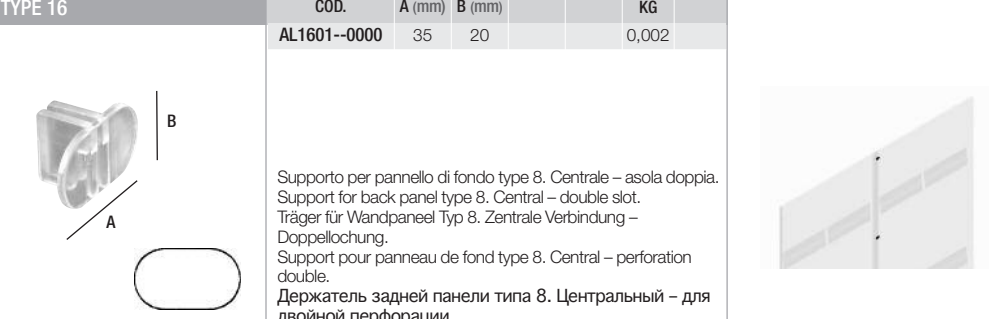

Supporto per pannello di fondo type 8. Centrale – asola doppia.
Support for back panel type 8. Central – double slot.
Träger für Wandpaneel Typ 8. Zentrale Verbindung – Doppelbohrung.
Support pour panneau de fond type 8. Central – perforation double.
Держатель задней панели типа 8. Центральный – для двойной перфорации.

TYPE 17	COD.	A (mm)	B (mm)		KG
	AL1701--0000	200	20°		0,4
	AL1702--0000	300	20°		0,6
	AL1703--0000	400	20°		0,7

Coppia mensole per ripiano dritto/inclinato 20°.
Straight/slanted shelving twins 20°.
Trägerpaar für gerades/schräges Fach 20°.
Couple supports pour étagère droite/inclinée 20°.
Пара держателей прямой/наклонной полки 20°.

TYPE 21	COD.	A (mm)		KG
	AL2101--0000	180		0,44

Coppia mensole per ripiano dritto/inclinato 20°.
Straight/slanted shelving twins 20°.
Trägerpaar für gerades/schräges Regal 20°.
Couple supports pour étagère droite/inclinée 20°.
Пара держателей прямой/наклонной полки 20°.

TYPE 18	COD.	A (mm)	B (mm)	C (mm)	KG
	AL1801--0000	600	35	10	0,98
	AL1802--0000	900	35	10	1,5

Coppia collegamento per ripiano in cristallo.
Crystal shelving holders.
Glasp Plattenträgerpaar.
Couple de jonctions pour étagère en cristal.
Пара держателей стеклянной полки.

TYPE 22	COD.	A (mm)	B (mm)	KG
	AL2201--0000	600	8	0,24
	AL2202--0000	900	8	0,36

Profilo in alluminio per ripiano in cristallo sp. 8.
Aluminium profile for crystal shelf th. 8.
Profil aus Aluminium für Glasfach D. 8.
Profil en aluminium pour étagère en cristal ép. 8.
Алюминиевый профиль для стеклянной полки толщ. 8.

TYPE 19	COD.	A (mm)	B (mm)	KG	📦
	AL1901--0000	600	90	0,8	30
	AL1902--0000	900	90	1,05	25

Barra appendideria aderente.
Adherent hanging bar.
Gerade Hängestange.
Barre d'accrochage.
Прилегающее вешало.

TYPE 23	COD.	A (mm)	B (mm)	KG
	AL2301--0000	600	18	0,113
	AL2302--0000	900	18	0,170

Profilo in alluminio per ripiano in legno type 24.
Aluminium profile for wooden shelf type 24.
Profil aus Aluminium für Holzfach Typ 24.
Profil en aluminium pour étagère en bois type 24.
Алюминиевый профиль для деревянной полки типа 24.

TYPE 20	COD.	A (mm)	B (mm)	KG	📦
	AL2001--0000	600	350	0,89	40
	AL2002--0000	900	350	1,32	35

Barra appendideria staccata.
Outdistanced hanging bar.
Lose Abhängestange.
Barre d'accrochage décalée.
Выступающее вешало.

TYPE 24	COD.	A (mm)	B (mm)	C (mm)	KG	📦
	AL2401--0000	600	400	18	3	30
	AL2402--0000	900	400	18	4,5	25

Ripiano in legno fresato.
Milled wooden shelf.
Gefrästes Holzfach.
Étagère rainurée en bois.
Деревянная полка с пазом.

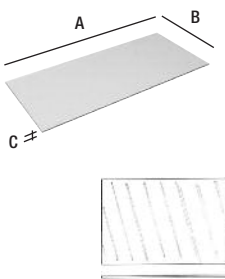
TYPE 25	COD.	A (mm)	B (mm)	C (mm)	KG	📦
	AL2501--0000	600	400	8	4,7	35
	AL2502--0000	900	400	8	7	30

Ripiano in cristallo.
Crystal shelf.
Glasfach.
Etagère en cristal.
Стеклопанельная полка.

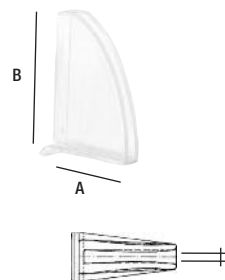

TYPE 26	COD.	A (mm)	B (mm)	C (mm)	KG	📦
	AL2601--0000	43,9	63	4	0,017	

Supporto portadivisorio per type 22-23.
Support for separator holder for type 22-23.
Träger für Glasplattenträger für Typ 22-23.
Support porte-séparation pour type 22-23.
Держатель разделителя.

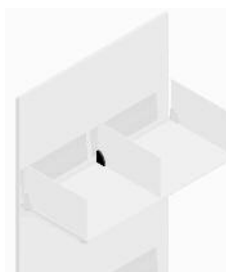

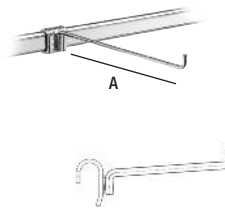
TYPE 27	COD.	A (mm)	KG	📦
	AL2701--0000	100	0,08	2
	AL2702--0000	150	0,09	2
	AL2703--0000	250	0,11	2

Barretta per barra appenderia.
Hook for hanging bar.
Aufhängehaken für Hängestange.
Tige pour barre d'accrochage.
Кронштейн с креплением к овальной перекладине.

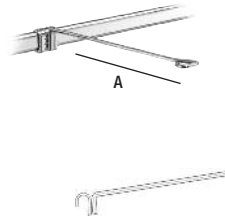

TYPE 28	COD.	A (mm)	KG	📦
	AL2801--0000	200	0,13	2
	AL2802--0000	300	0,15	2

Barretta portabilister semplice per barra appenderia.
Simple hook blister-holder for hanging bar.
Einfacher Aufhängehaken für Blister-Packungen für Hängestange.
Tige porte-blisters simple pour barre d'accrochage.
Кронштейн для блистера с креплением к овальной перекладине.

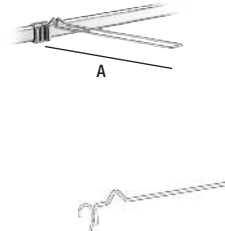

TYPE 29	COD.	A (mm)	KG	📦
	AL2901--0000	200	0,16	2
	AL2902--0000	300	0,19	2

Barretta portabilister doppia per barra appenderia.
Double hook blister-holder for hanging bar.
Doppelter Aufhängehaken für Blister-Packungen für Hängestange.
Tige porte-blisters double pour barre d'accrochage.
Кронштейн двойной для блистера с креплением к овальной перекладине.

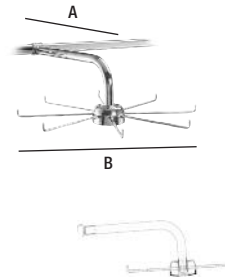

TYPE 30	COD.	A (mm)	B (mm)	KG	📦
	AL3001--0000	300	Ø440	1,17	8

Braccio appenderia girevole per barra appenderia.
Rotating hanging arm for hanging bar.
Drehbarer Abhängearm für Hängestange.
Bras d'accrochage tournant pour barre d'accrochage.
Кронштейн-карусель с креплением к овальной перекладине.

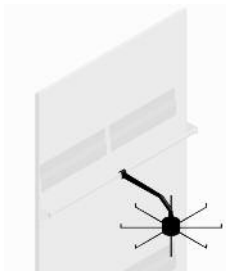

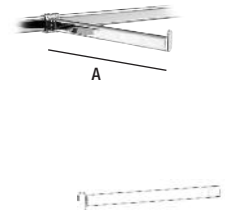
TYPE 31	COD.	A (mm)	KG	📦
	AL3101--0000	300	0,27	10



Barra diritta per barra appenderia.
Straight bar for hanging bar.
Gerade Stange für Hängestange.
Barre droite pour barre d'accrochage.
Прямой кронштейн с креплением к овальной перекладине.

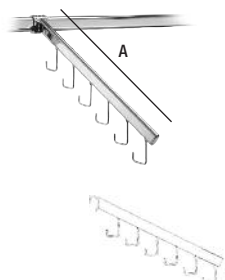

TYPE 32	COD.	A (mm)	KG	📦
	AL3201--0000	360	0,34	10

Barra inclinata con ganci per barra appenderia.
Slanted bar with hooks for hanging bar.
Schräge Stange mit Haken für Hängestange.
Barre inclinée avec crochets pour barre d'accrochage.
Наклонный кронштейн с крючками с креплением к овальной перекладине.

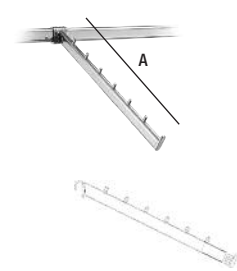

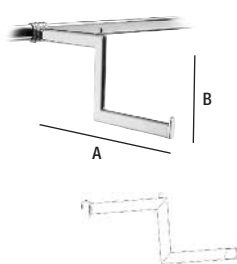
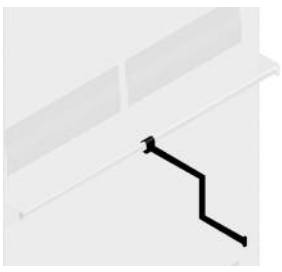

TYPE 33	COD.	A (mm)			KG	📦
	AL3301--0000	360			0,32	10
<p>Barra inclinata per barra appenderia. Slanted bar for hanging bar. Schräge Stange für Hängestange. Barre à marche pour barre d'accrochage. Ступенчатый кронштейн с креплением к овальной перекладине.</p> 						

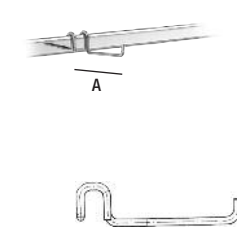
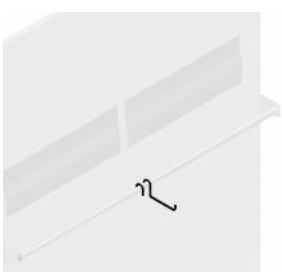

TYPE 34	COD.	A (mm)	B (mm)		KG	📦
	AL3401--0000	325	125		0,35	10
<p>Barra a gradino per barra appenderia. Step-shaped bar for hanging bar. Stufenförmige Stange für Hängestange. Barre à marche pour barre d'accrochage. Ступенчатый кронштейн с креплением к овальной перекладине.</p> 						

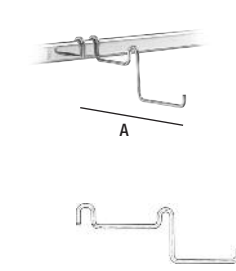
TYPE 35	COD.	A (mm)	B (mm)		KG	📦
	AL3501--0000	360	250		0,55	10
<p>Barra alzata inclinata per barra appenderia. Slanted raised bar for hanging bar. Schräge erhöhte Stange für Hängestange. Barre inclinée levée pour barre d'accrochage. Наклонный кронштейн с креплением к овальной перекладине.</p> 						

TYPE 36	COD.	A (mm)			KG	📦
	AL3601--0000	100			0,045	2
<p>Barretta per barra appenderia. Hook for hanging bar. Aufhängehaken für Hängestange. Tige pour barre d'accrochage. Крючок с креплением к овальной перекладине.</p> 						

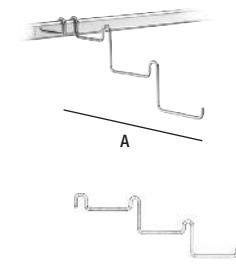
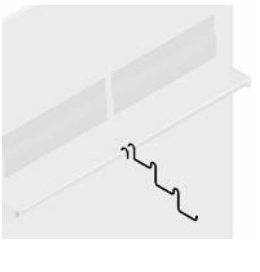
TYPE 37	COD.	A (mm)			KG	📦
	AL3701--0000	200			0,085	2
<p>Barretta a 2 gradini per barra appenderia. 2-step hook for hanging bar. 2-Stufen Aufhängehaken für Hängestange. Tige à 2 marches pour barre d'accrochage. 2-х-ступенчатый крючок с креплением к овальной перекладине.</p> 						

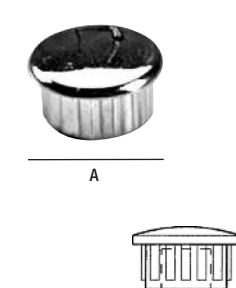
TYPE 38	COD.	A (mm)			KG	📦
	AL3801--0000	300			0,14	2
<p>Barretta a 3 gradini per barra appenderia. 3-step hook for hanging bar. 3-Stufen Aufhängehaken für Hängestange. Tige à 3 marches pour barre d'accrochage. 3-х-ступенчатый крючок с креплением к овальной перекладине.</p> 						

TYPE 39	COD.	A (mm)				
	AL3901--0000	Ø12				
<p>Copriforo per pannelli type 4. Hole cover for panels type 4. Bohrungabdeckung für Paneele Typ 4. Couverture pour trous des panneaux type 4. Заглушка для отверстия в панели типа 4.</p> 						

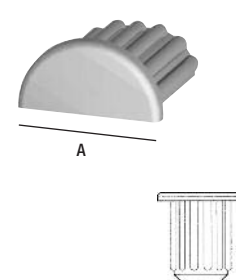
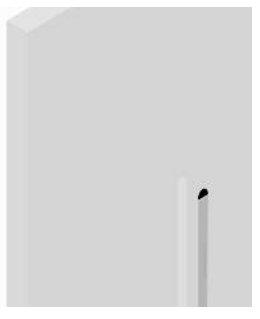
TYPE 40	COD.	A (mm)				
	AL4001--0000	10,5				
<p>Tappo chiusura fresatura pannelli type 4-10. Closing cap for panel slat type 4-10. Endkappe für Paneelfräsen Typ 4-10. Bouchon de fermeture pour rainures des panneaux type 4-10. Заглушка пазового профиля типа 4-10.</p> 						

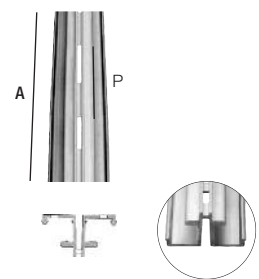
TYPE 41	COD.	A (mm)	P (mm)	KG
	AL4101--0000	2400	50	1,536
<p>Profilo centrale in alluminio per pannello fresato – Asola singola. Central aluminium profile for slatted panel – Single slot. Zentralprofil aus Aluminium für Paneel mit Lamellen – Einzelbohrung. Profil central en aluminium pour panneau rainuré – Perforation unique. Центральный алюминиевый профиль для панели с пазом – с одиночной перфорацией.</p> <p>P: passo/pitch/Teilung/empattement/шар</p>				

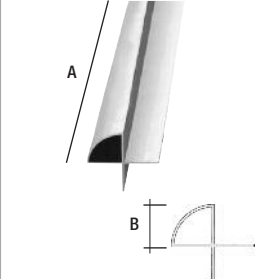
TYPE 45	COD.	A (mm)	B (mm)	KG
	AL4501--0000	2400	20,5	0,8
<p>Profilo stondato angolare in alluminio. Rounded angular aluminium profile. Abrundetes Eckprofil aus Aluminium. Profil arrondi angulaire en aluminium. Угловой закругленный алюминиевый профиль.</p>				

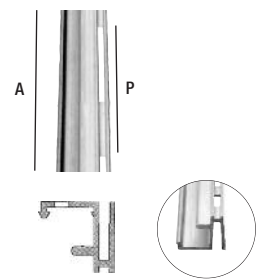
TYPE 42	COD.	A (mm)	P (mm)	KG
	AL4201--0000	2400	50	1,07
<p>Profilo laterale in alluminio per pannello fresato – Asola singola. Side aluminium profile for slatted panel – Single slot. Seitenprofil aus Aluminium für Paneel mit Lamellen – Einzelbohrung. Profil latéral en aluminium pour panneau rainuré – Perforation unique. Боковой алюминиевый профиль для панели с пазом – с одиночной перфорацией.</p> <p>P: passo/pitch/Teilung/empattement/шар</p>				

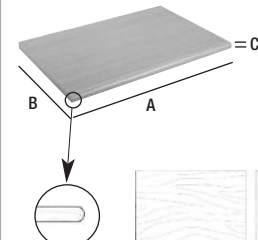
TYPE 46	COD.	A (mm)	B (mm)	C (mm)	KG	☰
	AL4601--0000	600	400	25	4,16	40
	AL4602--0000	900	400	25	6,25	35
<p>Ripiano in legno softformato. Wooden shelf with round edge (softforming). Holzfach mit rundetem Ende (softforming). Étagère en bois avec extrémité arrondie (softforming). Полка деревянная с закругленным бортиком.</p>						

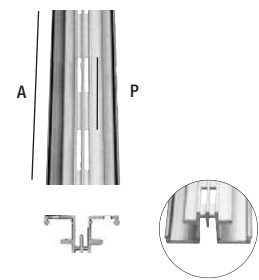
TYPE 43	COD.	A (mm)	P (mm)	KG
	AL4301--0000	2400	50	1,717
<p>Profilo centrale in alluminio per pannello fresato – Asola doppia. Central aluminium profile for slatted panel – Double slot. Zentralprofil aus Aluminium für Paneel mit Lamellen – Doppelbohrung. Profil central en aluminium pour panneau rainuré – Perforation double. Центральный алюминиевый профиль для панели с пазом – с двойной перфорацией.</p> <p>P: passo/pitch/Teilung/empattement/шар</p>				

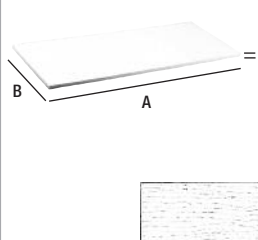
TYPE 47	COD.	A (mm)	B (mm)	C (mm)	KG	☰
	AL4701--0000	600	400	18	3	30
	AL4702--0000	900	400	18	4,5	25
<p>Ripiano in legno. Wooden shelf. Holzfach. Étagère en bois. Полка деревянная.</p>						

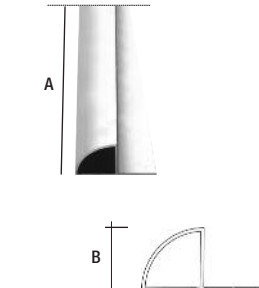
TYPE 44	COD.	A (mm)	B (mm)	KG
	AL4401--0000	2400	20,5	0,734
<p>Profilo stondato terminale in alluminio. Rounded end aluminium profile. Abrundetes Endprofil aus Aluminium. Profil arrondi final en aluminium. Терминальный закругленный алюминиевый профиль.</p>				

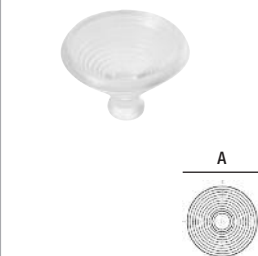
TYPE 48	COD.	A (mm)	KG
	AL4801--0000	Ø23	0,001
<p>Ventosa per ripiani in cristallo. Sucker for crystal shelves. Sauger für Glasfächer. Ventouse pour étagères en cristal. Присоска для стеклянной полки.</p>			

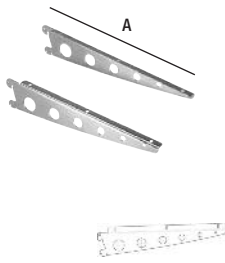
TYPE 49	COD.	A (mm)	KG
	AL4901--0000	350	0,76
<p>Coppia mensole con fori per ripiano diritto/inclinato 20°. Pair of pierced brackets for straight/slanted shelf 20°. Trägerpaar mit Löchern für gerades/schräges Regal 20°. Couple supports pour étagère droite/inclinée 20°. Пара полкодержателей с отверстиями для прямой/наклонной полки 20°.</p>			

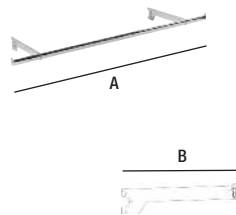
TYPE 53	COD.	A (mm)	B (mm)	KG	☒
	AL5301--0000	1185	330	1,56	30
<p>Barra appenderia staccata L=330. Outdistanced hanging bar L=330. Lose Abhänggestange L=330. Barre d'accrochage décalée L=330. Выступающее вешало L.330.</p>					

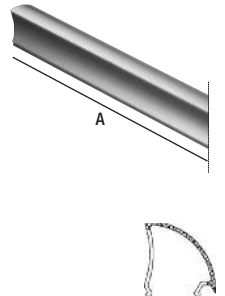
TYPE 50	COD.	A (mm)	KG
	AL5001--0000	2400	0,408
<p>Profilo raggiato di copertura. Covering radial profile. Strahlenförmiges Überprofil. Profil rayonné de couverture. Закругленный профиль.</p>			

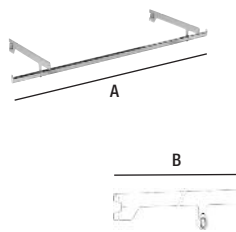
TYPE 54	COD.	A (mm)	B (mm)	KG	☒
	AL5401--0000	1185	435	1,8	30
<p>Coppia mensole per ripiano con barra appenderia. Brackets pair for shelf with hanging bar. Trägerpaar für Fach mit Hängestange. Couple supports pour étagère avec barre d'accrochage. Вешало для полки.</p>					

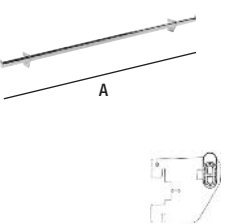
TYPE 51	COD.	A (mm)	KG	☒
	AL5101--0000	1185	1,21	20
<p>Barra appenderia aderente. Adherent hanging bar. Gerade Hängestange. Barre d'accrochage. Прилегающее вешало.</p>				

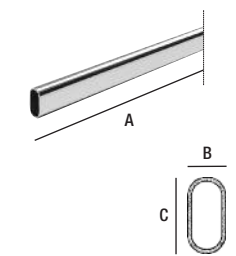
TYPE 55	COD.	A (mm)	B (mm)	C (mm)	KG
	AL5501--0000	3000	15	30	2,61
<p>Barra ovale. Oval bar. Ovalstange. Barre ovale. Овальная перекладина.</p>					

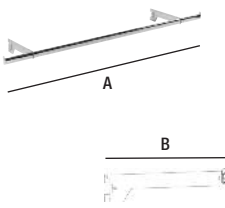
TYPE 52	COD.	A (mm)	B (mm)	KG	☒
	AL5201--0000	1185	270	1,475	30
<p>Barra appenderia staccata L=270. Outdistanced hanging bar L=270. Lose Abhänggestange L=270. Barre d'accrochage décalée L=270. Выступающее вешало L.270.</p>					

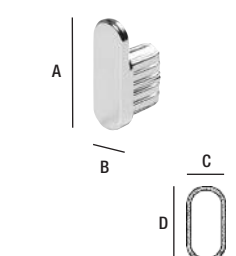
TYPE 56	COD.	A (mm)	B (mm)	C (mm)	D (mm)	KG
	AL5601--0000	42,5	15,5	15	30	0,006
<p>Fermacapo per barra ovale. Clothes-stopping element for oval bar. Haltestück für Ovalstange. Arrête-pièce pour barre ovale. Выступающая заглушка для овальной трубы.</p>						

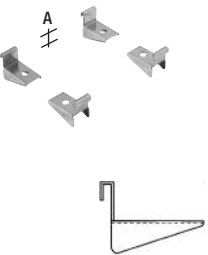
TYPE 57	COD.	A (mm)	KG
	AL5701--0000	12,8	0,029
<p>Set di supporti (n°4 pz.) ripiani in cristallo sp.8 mm per type 54-62. Set of brackets (4 pcs.) for crystal shelf th. 8 mm. for type 54-62. Trägersatz für Glasfächer (4 Stk) Dicke 8 mm. für Typ 54-62. Set de supports (4 pcs.) pour étagère en cristal d. 8 mm. pour type 54-62. Набор держателей (4 шт.) для стеклянных полок толщ. 8 мм для типа 54-62.</p>			

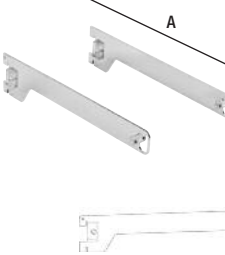
TYPE 61	COD.	A (mm)	KG
	AL6101--0000	330	0,550
<p>Coppia mensole per appenderia staccata L=330. Pair of brackets for hanging bar L=330. Trägerpaar für Hängestange L=330. Couple supports pour barre d'accrochage L=330. Пара держателей для выступающего вешала L.330.</p>			

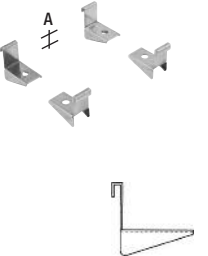
TYPE 58	COD.	A (mm)	KG
	AL5801--0000	19,8	0,032
<p>Set di supporti (n°4 pz.) ripiani in legno sp.18 mm per type 54-62. Set of brackets (4 pcs.) for wooden shelf th. 18 mm. for type 54-62. Trägersatz für Holzfach (4 Stk) Dicke 18 mm. für Typ 54-62. Set de supports (4 pcs.) pour étagère en bois d. 18 mm. pour type 54-62. Набор держателей (4 шт.) для деревянных полок толщ. 18 мм для типа 54-62.</p>			

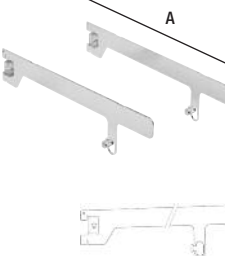
TYPE 62	COD.	A (mm)	KG
	AL6201--0000	435	0,775
<p>Coppia mensole per ripiano e appenderia staccata L=435. Pair of brackets for hanging bar L=435. Trägerpaar für Hängestange L=435. Couple supports pour barre d'accrochage L=435. Пара держателей для выступающего вешала L.435.</p>			

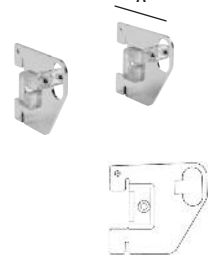
TYPE 59	COD.	A (mm)	KG
	AL5901--0000	75	0,185
<p>Coppia mensole per appenderia aderente. Pair of brackets for hanging bar. Trägerpaar für gerade Hängestange. Couple supports pour barre d'accrochage. Пара держателей для прилегающего вешала.</p>			

TYPE 63	COD.	A (mm)	KG
	AL6301--0000	Ø14	0,001
<p>Ventosa per ripiani in cristallo con type 54-62. Suction caps for crystal shelves with types 54-62. Säuger für Glasfachböden mit Typen 54-62. Ventouse pour étagères en cristal avec type 54-62. Присоска для стеклянной полки с типом 54-62.</p>			

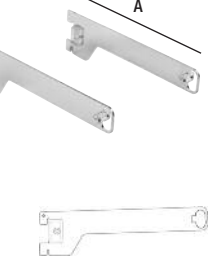
TYPE 60	COD.	A (mm)	KG
	AL6001--0000	270	0,45
<p>Coppia mensole per appenderia staccata L=270. Pair of brackets for hanging bar L=270. Trägerpaar für Hängestange L=270. Couple supports pour barre d'accrochage L=270. Пара держателей для выступающего вешала L.270.</p>			

STRUTTURA A PARETE WALL STRUCTURE

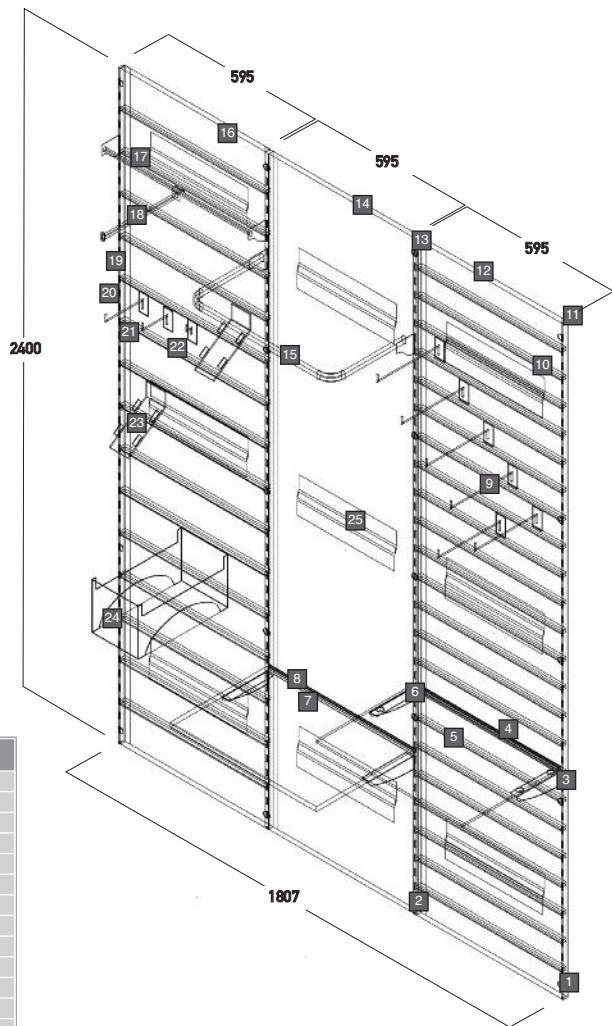

POS	SYSTEM	TYPE	A (mm)	B (mm)	C (mm)	PCS
1	ALIAS	14	18,5	20		5
2	ALIAS	16	35	20		10
3	ALIAS	21	180			2
4	ALIAS	22	600	8		1
5	ALIAS	25	600	400	8	1
6	ALIAS	48	Ø23			4
7	ALIAS	24	600	400	18	1
8	ALIAS	23	600	18		1
9	SLATBOARD	19	250			6
10	ALIAS	7	595			38
11	ALIAS	2	2400			2
12	ALIAS	5	595	2400	19	1
13	ALIAS	3	2400			2
14	ALIAS	8	595	2400	19	1
15	ALIAS	20	600	350		1
16	ALIAS	6	595	2400	19	1
17	ALIAS	19	600	90		1
18	ALIAS	31	300			1
19	ALIAS	13	18,5	20		5
20	SLATBOARD	63	150			1
21	SLATBOARD	63	100			1
22	SLATBOARD	64	21			1
23	SLATBOARD	69	77	188		2
24	SLATBOARD	73	190	375	204	1
25	ALIAS	12	400			9

STRUTTURA A PARETE WALL STRUCTURE

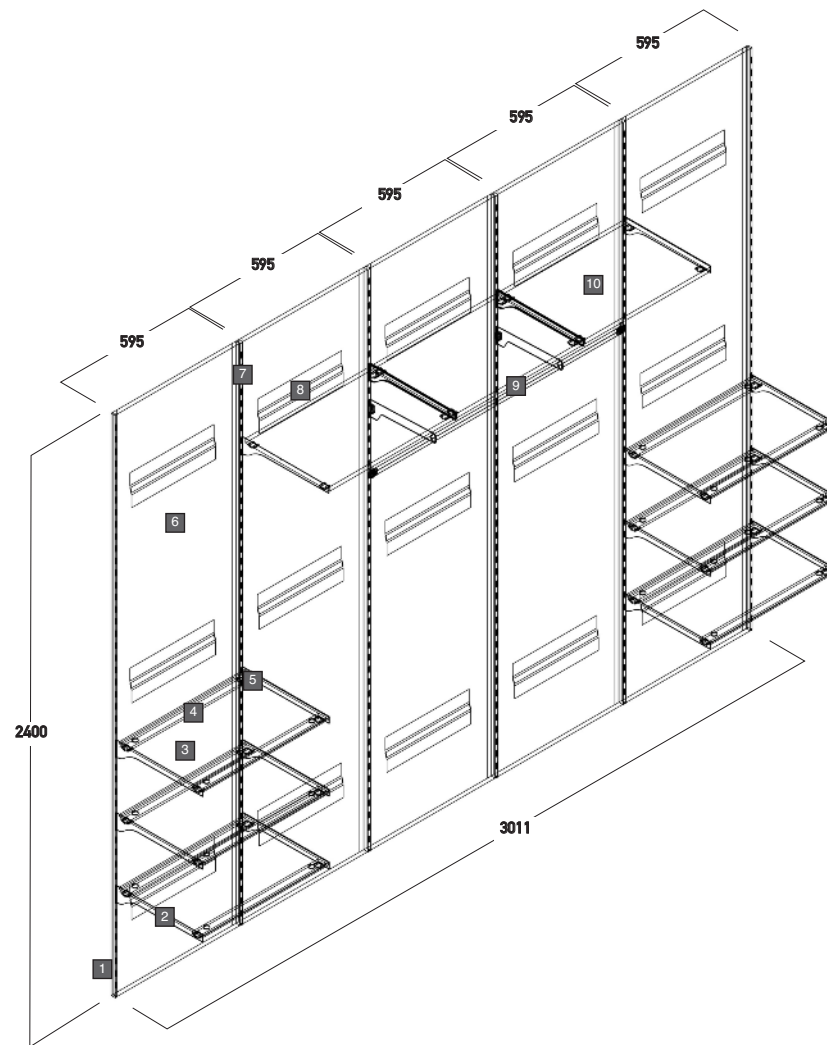

POS	SYSTEM	TYPE	A (mm)	B (mm)	C (mm)	PCS
1	ALIAS	2	2400			2
2	ALIAS	17	400	20°		9
3	ALIAS	25	600	400	8	6
4	ALIAS	18	600	35	10	6
5	ALIAS	48	Ø23			24
6	ALIAS	8	595	2400	19	5
7	ALIAS	3	2400			4
8	ALIAS	12	400			15
9	ALIAS	53	1185	330		1
10	ALIAS	47	600	400	18	3

STRUTTURA A PARETE WALL STRUCTURE

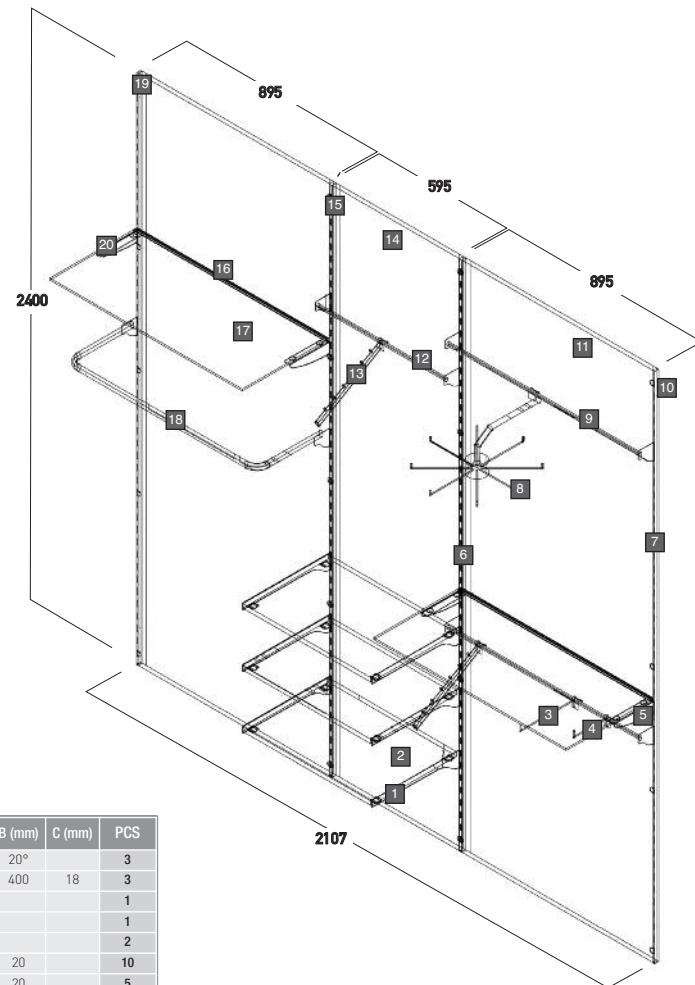

POS	SYSTEM	TYPE	A (mm)	B (mm)	C (mm)	PCS
1	ALIAS	17	400	20°		3
2	ALIAS	24	600	400	18	3
3	ALIAS	27	250			1
4	ALIAS	27	150			1
5	ALIAS	21	180			2
6	ALIAS	16	35	20		10
7	ALIAS	14	18,5	20		5
8	ALIAS	30	300	Ø400		1
9	ALIAS	19	900	90		2
10	ALIAS	2	2400			2
11	ALIAS	8	895	2400	19	2
12	ALIAS	19	600	90		1
13	ALIAS	33	360			2
14	ALIAS	8	595	2400	19	1
15	ALIAS	3	2400			2
16	ALIAS	22	900	8		2
17	ALIAS	25	900	400	8	2
18	ALIAS	20	900	350		1
19	ALIAS	13	18,5	20		5
20	ALIAS	48	Ø23			8

GONDOLA GONDOLA

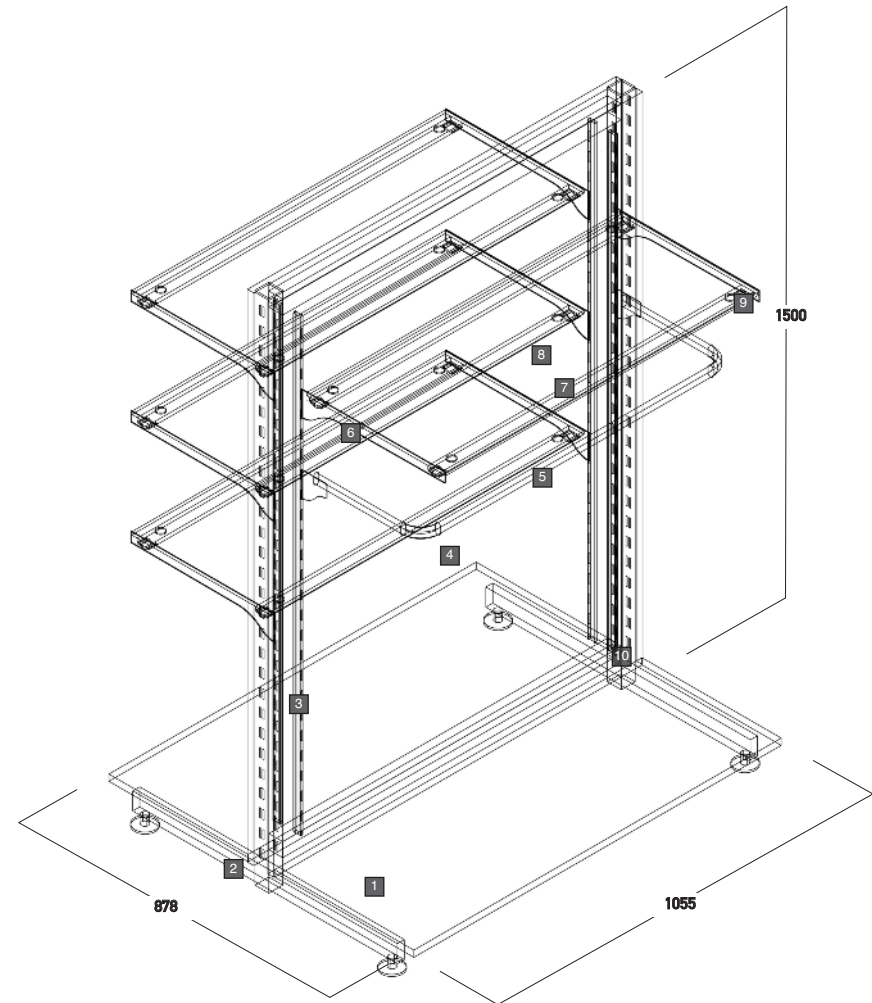

POS	SYSTEM	TYPE	A (mm)	B (mm)	C (mm)	PCS
1	ALIAS	11	1055	400	18	2
2	ALIAS	9	1052	760	1475	1
3	ALIAS	1	1290			4
4	ALIAS	10	1055	1425	19	2
5	ALIAS	20	900	350		1
6	ALIAS	17	400	20°		4
7	ALIAS	18	900	35	10	4
8	ALIAS	25	900	400	8	4
9	ALIAS	48	Ø23			16
10	ALIAS	40	10,5			8

MONTAGGIO DI PANNELLI FRESATI A PARETE FIXING OF SLATTED PANELS TO THE WALL

MONTAGGIO A PARETE DEI PANNELLI DI FONDO FIXING OF BACK PANELS TO THE WALL

1
FISSARE AL MURO IL PROFILO LATERALE ASOLATO UTILIZZANDO GLI APPOSITI TASSELLI A SECONDA DEL TIPO DI MURO. SECURE THE LATERAL SLOTTED PROFILE TO THE WALL USING THE APPROPRIATE BOLTS, DEPENDING ON THE WALL TYPE.

2
ACCOSTARE IL PANNELLO IN LEGNO FINO AD INSERIRE LA FRESATURA NELL'ALETTA DEL PROFILO LATERALE ASOLATO. APPROACH THE WOODEN PANEL TO THE PROFILE AND INSERT THE MILLED SIDE INTO THE FIN OF THE LATERAL SLOTTED PROFILE.

3
ACCOSTARE IL PROFILO CENTRALE ASOLATO FINO AD INSERIRE L'ALETTA NELLA FRESATURA DEL PANNELLO IN LEGNO. APPROACH THE CENTRAL SLOTTED PROFILE TO THE WALL USING THE APPROPRIATE BOLTS, DEPENDING ON THE WALL TYPE.

4
FISSARE AL MURO IL PROFILO CENTRALE ASOLATO UTILIZZANDO GLI APPOSITI TASSELLI A SECONDA DEL TIPO DI MURO. SECURE THE CENTRAL SLOTTED PROFILE TO THE WALL USING THE APPROPRIATE BOLTS, DEPENDING ON THE WALL TYPE.

5
ACCOSTARE IL PANNELLO IN LEGNO FINO AD INSERIRE LA FRESATURA NELL'ALETTA DEL PROFILO CENTRALE ASOLATO. APPROACH THE WOODEN PANEL TO THE PROFILE AND INSERT THE MILLED SIDE INTO THE FIN OF THE CENTRAL SLOTTED PANEL.

6
RIPETERE LE OPERAZIONI REPEAT OPERATIONS (3) - (4)

7
7- FISSARE SUL LATO DEL PANNELLO IN LEGNO IL PROFILO LATERALE ASOLATO UTILIZZANDO LE VITI PER TRUCIOLARE. SECURE THE LATERAL SLOTTED PROFILE TO THE WOODEN PANEL USING CHIPBOARD SCREWS.
8- FISSARE SUL RETRO DEL PANNELLO IN LEGNO IL PROFILO IN ALLUMINIO UTILIZZANDO LE VITI PER TRUCIOLARE. SECURE THE ALUMINIUM PROFILE TO THE REAR SIDE OF THE PANEL USING CHIPBOARD SCREWS.

8

9
ACCOSTARE IL PANNELLO IN LEGNO FINO AD INSERIRE LA FRESATURA NELL'ALETTA DEL PROFILO CENTRALE ASOLATO. APPROACH THE WOODEN PANEL TO THE PROFILE AND INSERT THE MILLED SIDE INTO THE FIN OF THE CENTRAL SLOTTED PROFILE.

1
FISSARE AL MURO I PROFILI ASOLATI. UTILIZZARE GLI APPOSITI TASSELLI A SECONDA DEL TIPO DI MURO. SECURE THE SLOTTED PROFILE TO THE WALL USING THE APPROPRIATE BOLTS DEPENDING ON THE WALL TYPE.

2
POSIZIONARE I PANNELLI TRA I PROFILI ASOLATI, IN DIREZIONE DEL MURO. POSITION THE PANELS BETWEEN THE SLOTTED PROFILES TOWARDS THE WALL.

3
INSERIRE I SUPPORTI IN PLASTICA ALL'INTERNO DELLE ASOLE. INSERT THE PLASTIC SUPPORTS INTO THE SLOTS.

MONTAGGIO A PARETE DI PANNELLI DOGATI ASSEMBLY OF SLATTED PANELS TO THE WALL

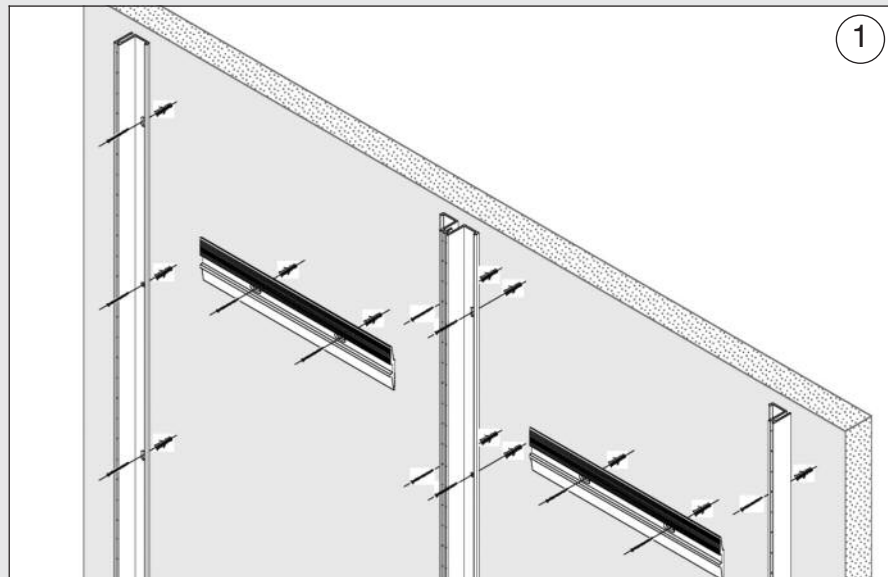

FISSARE AL MURO I PROFILI ASOLATI E I PROFILI IN ALLUMINIO. UTILIZZARE GLI APPOSITI TASSELLI A SECONDA DEL TIPO DI MURO.
SECURE THE SLOTTED PROFILES AND THE ALUMINIUM PROFILES TO THE WALL. USE THE APPROPRIATE BOLTS DEPENDING ON THE WALL TYPE.

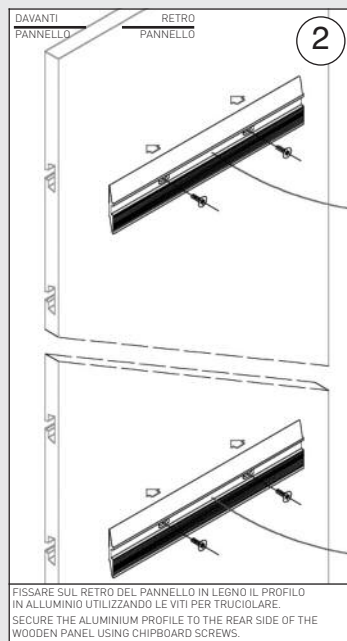

FISSARE SUL RETRO DEL PANNELLO IN LEGNO IL PROFILO IN ALLUMINIO UTILIZZANDO LE VITI PER TRUCIOLARE.
SECURE THE ALUMINIUM PROFILE TO THE REAR SIDE OF THE WOODEN PANEL USING CHIPBOARD SCREWS.

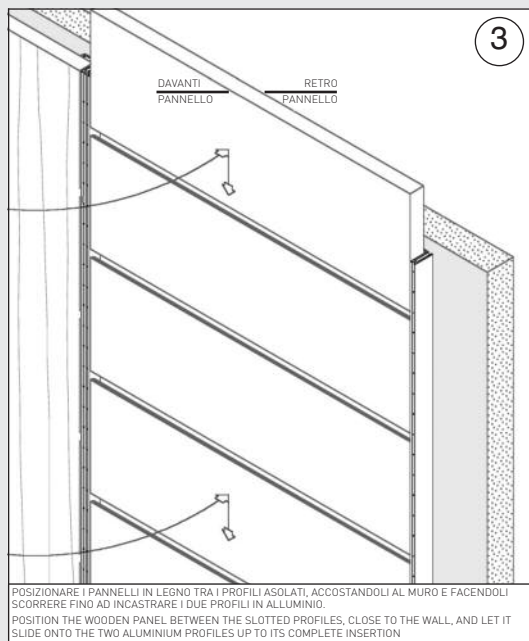

POSIZIONARE I PANNELLI IN LEGNO TRA I PROFILI ASOLATI, ACCOSTANDOLI AL MURO E FACENDOLI SCORRERE FINO AD INCASTRARE I DUE PROFILI IN ALLUMINIO.
POSITION THE WOODEN PANEL BETWEEN THE SLOTTED PROFILES, CLOSE TO THE WALL, AND LET IT SLIDE ONTO THE TWO ALUMINIUM PROFILES UP TO ITS COMPLETE INSERTION

MONTAGGIO A PARETE DI PANNELLI DOGATI DI FONDO ASSEMBLY OF SLATTED BACK PANELS TO THE WALL

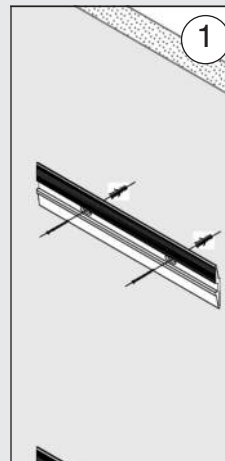

FISSARE AL MURO I PROFILI IN ALLUMINIO UTILIZZANDO GLI APPOSITI TASSELLI A SECONDA DEL TIPO DI MURO.
SECURE THE ALUMINIUM PROFILES TO THE WALL USING THE APPROPRIATE BOLTS DEPENDING ON THE WALL TYPE

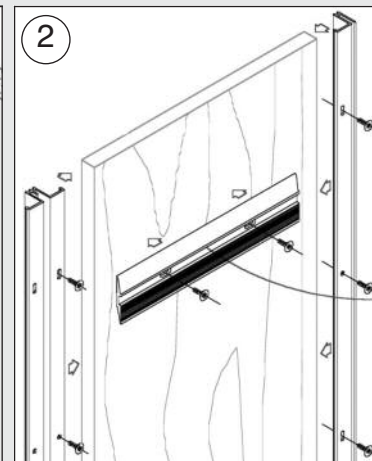

FISSARE SUI LATI DEL MANNELLO IN LEGNO I PROFILI ASOLATI E SUL RETRO IL PROFILO IN ALLUMINIO. UTILIZZARE LE VITI PER TRUCIOLARE.
SECURE THE SLOTTED PROFILES TO THE SIDES OF THE WOODEN PANEL AND THE ALUMINIUM PROFILE TO THE REAR SIDE OF THE PANEL USING CHIPBOARD SCREWS.

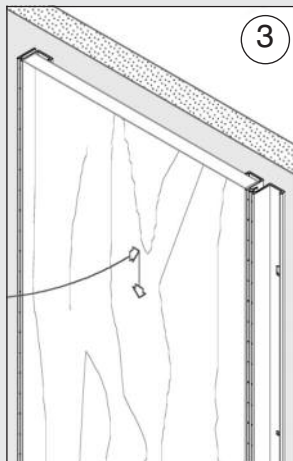

POSIZIONARE IL PANNELLO IN LEGNO ACCOSTANDOLO AL MURO E FARLO SCORRERE FINO AD INCASTRARE I DUE PROFILI IN ALLUMINIO.
POSITION THE WOODEN PANEL BETWEEN THE SLOTTED PROFILES, CLOSE TO THE WALL, AND LET IT SLIDE ONTO THE TWO ALUMINIUM PROFILES UP TO ITS COMPLETE INSERTION

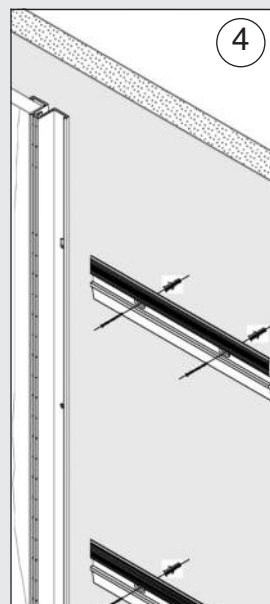

FISSARE AL MURO I PROFILI IN ALLUMINIO UTILIZZANDO GLI APPOSITI TASSELLI A SECONDA DEL TIPO DI MURO.
SECURE THE ALUMINIUM PROFILES TO THE WALL USING THE APPROPRIATE BOLTS DEPENDING ON THE WALL TYPE.

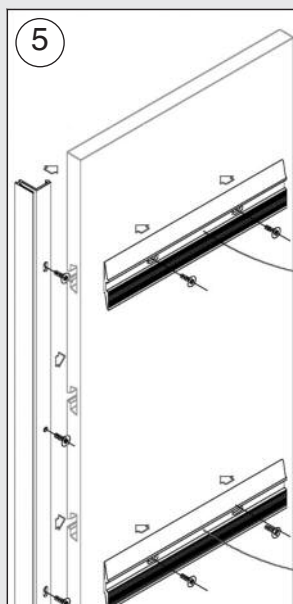

FISSARE SUL LATO DEL MANNELLO IN LEGNO IL PROFILO LATERALE ASOLATO (TERMINALE) E SUL RETRO IL PROFILO IN ALLUMINIO. UTILIZZARE LE VITI PER TRUCIOLARE.
SECURE THE SLOTTED LATERAL (HALFEND SLAT) PROFILE TO THE PANEL SIDE AND TO THE ALUMINIUM PROFILE. USE CHIPBOARD SCREWS.

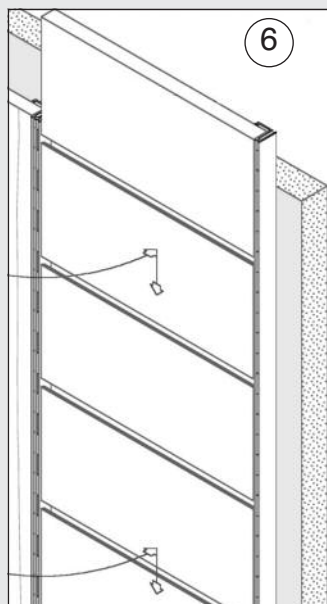

FISSARE SUL LATO DEL MANNELLO IN LEGNO IL PROFILO LATERALE ASOLATO (TERMINALE) E SUL RETRO IL PROFILO IN ALLUMINIO. UTILIZZARE LE VITI PER TRUCIOLARE.
SECURE THE LATERAL SLOTTED PROFILE (HALFEND SLAT) TO THE WOODEN PANEL AND TO THE REAR OF THE ALUMINIUM PROFILE. USE CHIPBOARD SCREWS.

MONTAGGIO A PARETE DEL PANNELLO DI FONDO TP. 4 ASSEMBLY OF SLATTED BACK PANEL TP 4 TO THE WALL

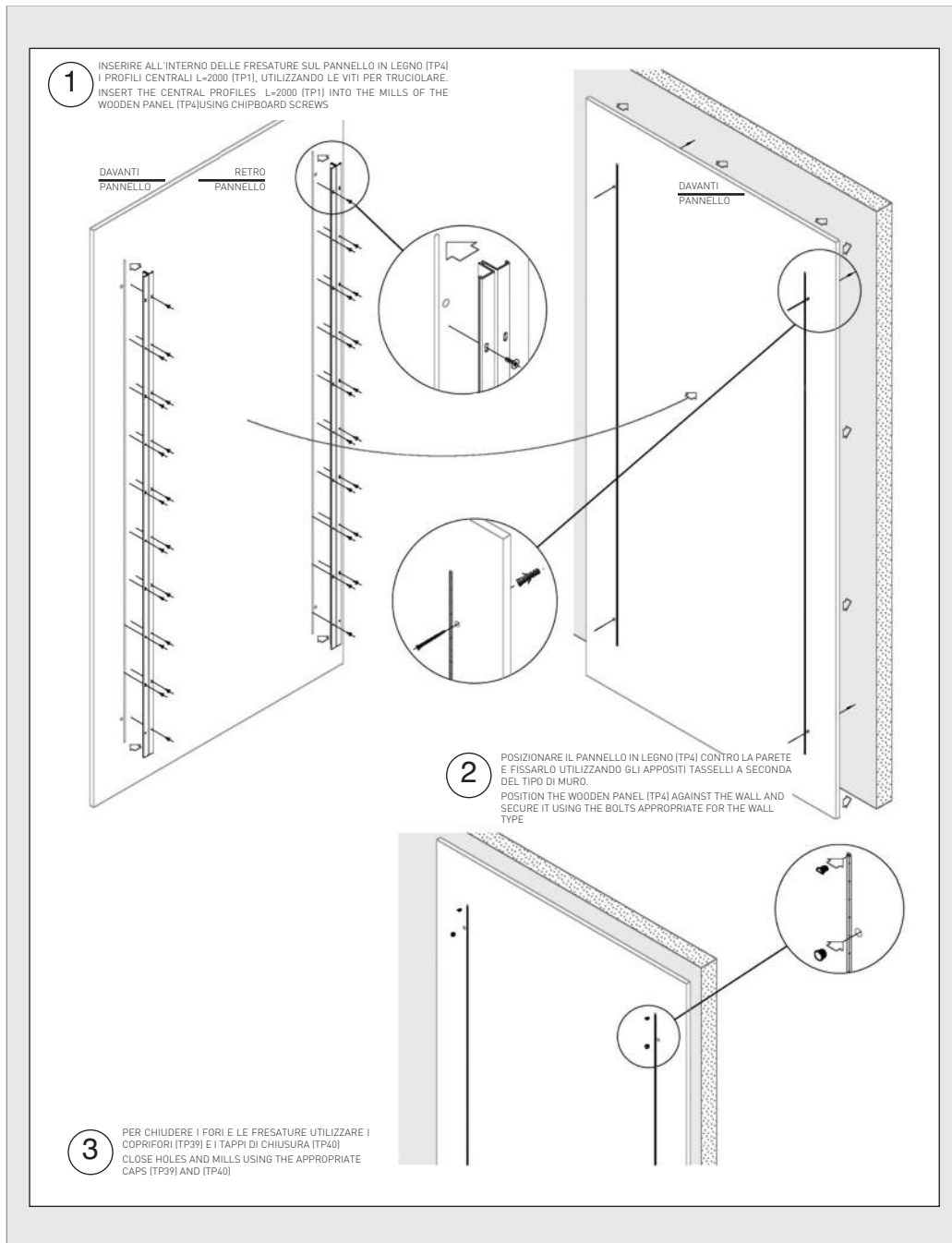

MONTAGGIO TELAIO PER GONDOLA ASSEMBLY OF GONDOLA FRAME

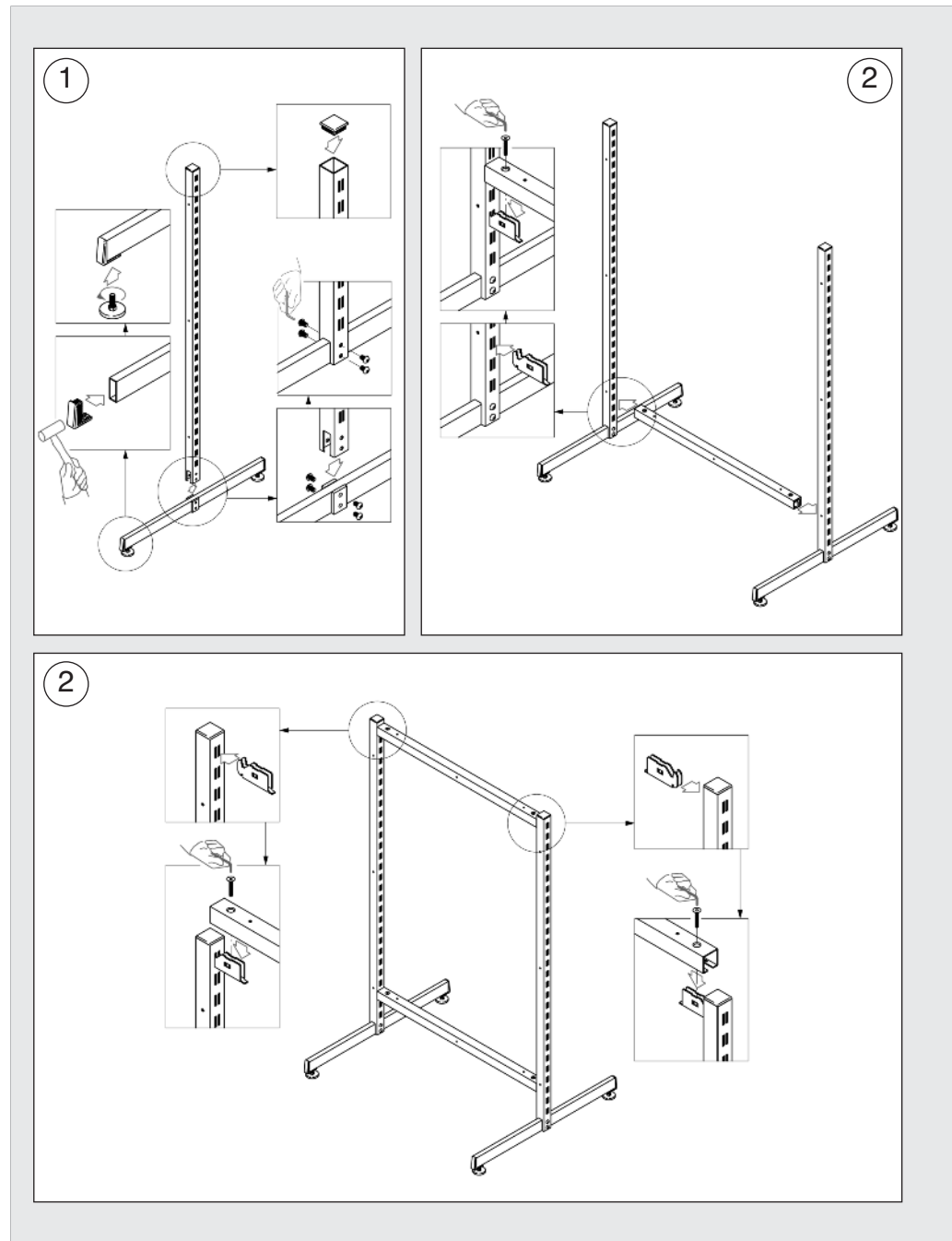

artheta[®]
IIII GROUP

ARTHEMAGROUP s.r.l.

Via Cascina Restelli, 5 - 20040 Aicurzio (MI) Italy
Tel. +39 0396093099 - Fax +39 0396093307
arthemagroup@arthemagroup.it - www.arthemagroup.it

PATENTED[®]